

Grease lubrication pump

EP-1 / FKGGM-EP

without control unit / with integrated control unit

BEKA-troniX1 / EP-tronic / EP-tronic T1 / EP-T2

Code 2018 ...; 2037 ...; 2152 ...;
2157 ...; 2175 ...; 2183 ...; 2184 ...

Issue of 12-2021

Original operating and assembly instructions



10177337

BAL_EP-1_FKGGM-EP_1221DE_EN_FR_IT_ES

Table of contents

1.	Technical data	81
1.1	Reservoir	82
1.2	Version of the device	82
1.2.1	Version without integrated control unit	82
1.2.2	Version with integrated control unit	83
2.	Further applicable documents	84
3.	General safety instructions	84
3.1	Safety instructions	84
3.2	Personnel qualification and personnel training	84
3.3	Dangers at non-observance of the safety instructions	85
3.4	Obligations of the operator / users	85
3.5	Safety instructions for maintenance, inspection and assembly work	85
3.6	Independent conversion and spare parts production	85
3.7	Inadmissible operating modes	86
3.8	Electrostatic discharge	86
3.9	General danger warning - residual risk	86
4.	Intended use	86
5.	Scope of warranty	87
6.	Transport and storage	87
7.	Assembly instructions	88
7.1	Line assembly	88
7.2	Electrical connection	88
7.2.1	Connection diagram for devices in version without control unit, without plug connection	88
7.2.2	Connection diagram for devices in DC version without control unit, with bayonet plug connection	89
7.2.3	Connection diagram for devices in AC version without control unit, with Hirschmann plug connection	89
7.2.4	Connection diagram for devices with BEKA-troniX1 with bayonet plug connection	90
7.2.5	Connection diagram for devices with BEKA-troniX1 with bayonet plug connection and plug connections M12x1	91
7.2.6	Connection diagram for devices with EP-tronic with bayonet plug connection	92
7.2.7	Connection diagram for devices with EP-tronic with Hirschmann plug connection	93
7.2.8	Connection diagram for devices with EP-tronic T1 with bayonet plug connection	94
7.2.9	Connection diagram for devices with EP-tronic T1 with Hirschmann plug connection	94
7.2.10	Connection diagram for devices with EP-T2	94
7.2.11	Connection diagram for level monitoring with cable socket EN 175301-803A	95
7.2.12	Connection diagram for level monitoring with plug connection M12x1	95
7.3	Assembly of the pump elements	95
7.3.1	Removal of a pump element	95
7.3.2	Installation of a pump element	96
8.	Commissioning	98
8.1	Lubricants	98
8.2	Lubricant filling	98
8.2.1	Filling via conical lubrication nipple with filling press (standard)	99
8.2.2	Filling via filling connection and filling pump	99
8.2.3	Filling via filling connection and manual grease gun	100
8.3	Checking the direction of rotation of the device	100
8.4	Venting of the lubrication system	100
9.	Function description	101
9.1	General	101
9.2	Structure of the device	102
9.3	Functional description of the device	104
9.4	Pump elements	105
9.4.1	Pump elements PE-120 V	105
9.4.2	Pump elements PE-60, PE-120 and PE-170	106
9.4.3	Order numbers of the pump elements	107
9.5	Pressure relief valves	107
9.5.1	Pressure relief valves without microswitch	107
9.5.2	Pressure relief valves with microswitch	108
10.	Level monitoring	110

10177337

BAL_EP-1_FKGGM-EP_1221DE_EN_FR_IT_ES

10.1	Technical data	111
10.2	MIN level.....	112
10.2.1	Functionality NO contact.....	112
10.2.2	Functionality NC contact.....	113
10.3	MAX level	113
10.3.1	Functionality NO contact.....	113
10.3.2	Functionality NC contact.....	113
10.4	Code of the level monitoring.....	114
10.4.1	Level monitoring with plug connection M12x1	114
10.4.2	Level monitoring with cable socket EN 175301-803 A.....	114
11.	Integrated control unit.....	115
11.1	BEKA-troniX1	115
11.1.1	Function description.....	116
11.1.2	Changing and setting the parameters.....	117
11.1.3	Operating mode time-dependent cycle duration	117
11.1.4	Operating mode time-dependent lubrication time.....	117
11.1.5	Operating mode rotation-dependent lubrication time.....	118
11.1.6	<i>Level monitoring</i> function.....	118
11.1.7	<i>System pressure monitoring</i> function.....	118
11.2	EP-tronic.....	119
11.2.1	Function description.....	120
11.2.2	Changing and setting the parameters.....	121
11.2.3	Operating mode time-dependent cycle duration	121
11.2.4	Operating mode time-dependent lubrication time.....	122
11.2.5	Operating mode time-dependent lubrication time.....	122
11.2.6	Operating mode rotation-dependent lubrication time.....	123
11.2.7	<i>Level monitoring</i> function.....	123
11.2.8	<i>System pressure monitoring</i> function.....	123
11.2.9	<i>Special function adaptation to operating conditions</i>	124
11.2.10	<i>Special function cycle locked</i>	124
11.2.11	<i>Special function external status signal</i>	125
11.3	EP-tronic T1.....	125
11.3.1	Function description.....	126
11.3.2	Changing and setting the parameters.....	127
11.3.3	Operating mode time-dependent cycle duration	127
11.3.4	Operating mode time-dependent lubrication time.....	127
11.4	EP-T2	128
11.4.1	Function description.....	129
11.4.2	Setting the parameters.....	129
11.4.3	Operating mode time-dependent lubrication time.....	130
12.	Maintenance	131
12.1	General maintenance.....	131
12.2	Lubricant change.....	131
12.3	Changing the integrated control unit.....	131
13.	Decommissioning	131
14.	Disposal.....	131
15.	Troubleshooting.....	132
15.1	Troubleshooting for devices without integrated control unit	132
15.2	Troubleshooting for device with integrated control unit.....	132
15.3	Signal indicators of the integrated control unit.....	133
15.3.1	Signal indicators BEKA-troniX1	134
15.3.2	Signal indicators EP-tronic.....	135
15.3.3	Signal indicators EP-tronic T1.....	136
16.	Code.....	137
16.1	Code for devices FKGGM-EP without control unit type 2018.....	137
16.2	Code for devices FKGGM-EP without control unit type 2037.....	138
16.3	Code for devices EP-1 without control unit type 2152.....	139
16.4	Code for devices EP-1 with BEKA-troniX1 type 2175.....	140
16.5	Code for devices EP-1 with EP-tronic type 2157.....	141

16.6	Code for devices EP-1 with EP-tronic T1 type 2183	142
16.7	Code for devices EP-1 with EP-T2 Type 2184	143
16.8	Code for control units	144
16.8.1	Code for BEKA-troniX1 type 2175	144
16.8.2	Code for EP-tronic type 2157	145
16.8.3	Code for EP-tronic T1 type 2183	146
16.8.4	Code for EP-T2 type 2184	146
17.	Spare parts list and drawing	146
18.	Dimensional drawings	147
18.1	Dimensional drawing for devices with 1,9 l	147
18.2	Dimensional drawing for devices with 2,5 l	148
18.3	Dimensional drawing for devices with 4,0 l	149
18.4	Dimensional drawing for devices with 8,0 l	150
18.5	Dimensional drawing for devices with 16,0 l	151
19.	Details of the manufacturer	152

1. Technical data

General:

Flow rate per stroke and outlet: depending on pump element (see chapter 9.4 "Pump elements")	
Number of outlets:	max. 3
Pressure connection:	Ø6 mm, Ø8 mm, Ø10 or G1/4" thread (see chapter 16 "Code")
Conveyed medium:	Greases up to NLGI class 2 (greases with solid content on request)
Operating pressure:	max. 350 bar
Pressure relief valve:	set at 290 bar (standard)
Operating temperature:	-20°C to +70°C (depending on the lubricant used)
Transport and storage temperature:	-40°C to +70°C
Reservoir material, size and usable volume:	see chapter 1.1 "Reservoir"
Installation position:	Vertical standing reservoir
Level monitoring:	optional (see chapter 10 "Level monitoring")
Direction of rotation of the agitator blade:	in the direction of the arrow (see sticker on reservoir)
Protection class:	IP 65
Weight:	without pump element and without control unit, with basic filling, depending on equipment
Plastic reservoir 1.9 l / 2.5 l / 4.0 l / 8.0 l / 16.0 l:	approx. 5.3 kg / approx. 6.2 kg / approx. 7.2 kg / approx. 10.2 kg / approx. 10.8 kg
Sound pressure level:	<70dB(A)

Motor:

Drive:	Gear motor
Current type:	Direct current
Tension:	12 or 24 V DC
Rated current max:	2.2 A at 12 V 1.1 A at 24 V
Pump speed:	15 rpm
Fuse (not included in the device):	5 A (12 V) 3 A (24 V)

Transformer (for FKGGM-EP version AC):

Input voltage:	230 V AC / 50 - 60 Hz 115 V AC / 50 - 60 Hz
----------------------	--

10177337

BAL_EP-1_FKGGM-EP_1221DE_EN_FR_IT_ES

Integrated control unit BEKA-troniX1, EP-tronic, EP-tronic T1:

Supply voltage: 10 to 60 V DC
 Current load max:6.0 A
 Output for signal lamp:0.4 A
 Fuse (not included in the device):6.3 A
 Protection class:IP 65

Integrated control unit EP-T2:

Supply voltage: 10 to 33 V DC
 Current load max:6.0 A
 Output for signal lamp:0.4 A
 Fuse (not included in the device):6.3 A
 Protection class:IP 65

The **grease lubrication pump EP-1 / FKGGM-EP** is referred to below as **device**.

1.1 Reservoir

Material	Size	Useful volume
Plastic, transparent	1.9 l	1.4 l
	2.5 l	2.0 l
	4.0 l	3.5 l
	8.0 l	6.7 l
	16.0 l	14.5 l

1.2 Version of the device

You can recognise the version of your device by the electrical connections provided and by the sticker in the viewing window of the protective housing.

1.2.1 Version without integrated control unit

Fig. 1:

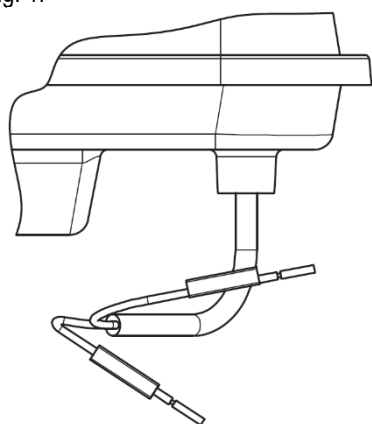

without viewing window
 without cable socket
Device in version without control unit, without plug connection
 Connection diagram see chapter 7.2.1

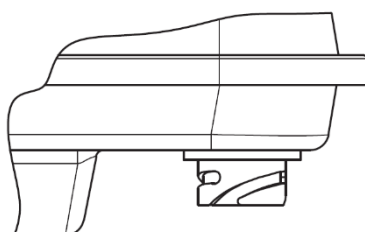

without viewing window
 with bayonet plug connection
Device in DC version without control unit, with bayonet plug connection
 Connection diagram see chapter 7.2.2

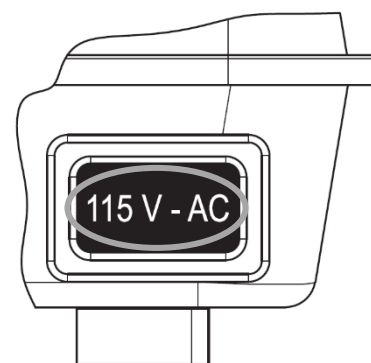

115 V - AC or 230 V - AC in the viewing window
 with Hirschmann plug connection
Device in AC version without control unit, with Hirschmann plug connection
 Connection diagram see chapter 7.2.3

10177337

BAL_EP-1_FKGGM-EP_1221DE_EN_FR_IT_ES

1.2.2 Version with integrated control unit

Fig. 2:

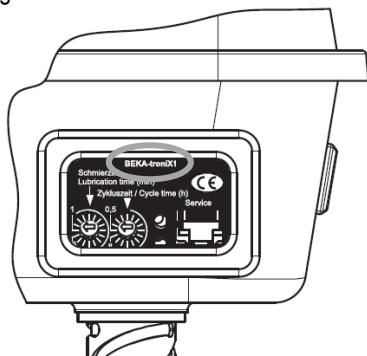

BEKA-troniX1 in the viewing window with bayonet plug connection and without additional plug connections

Device with BEKA-troniX1

Connection diagram see chapter 7.2.4

for function see chapter 11.1

Signal indicators see chapter 15.3.1

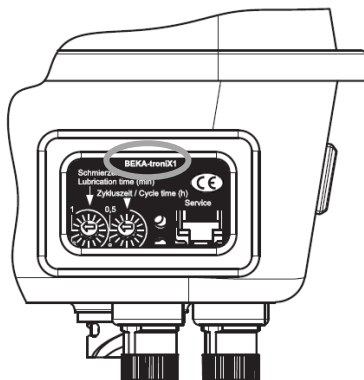

BEKA-troniX1 in the viewing window with bayonet plug connection and plug connections M12x1

Device with BEKA-troniX1

Connection diagram see chapter 7.2.5

for function see chapter 11.1

Signal indicators see chapter 15.3.1

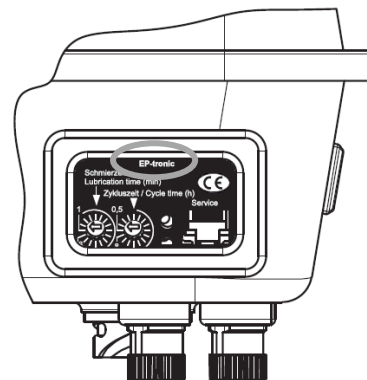

EP-tronic in the viewing window with bayonet plug connection and plug connections M12x1

Device with EP-tronic with bayonet plug connection

Connection diagram see chapter 7.2.6

for function see chapter 11.2

Signal indicators see chapter 15.3.2

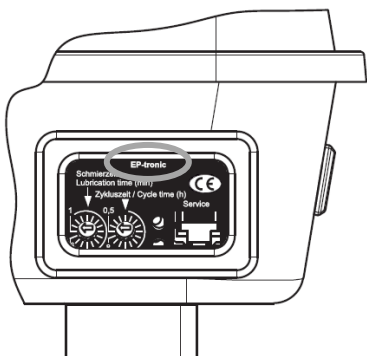

EP-tronic in the viewing window with 2x Hirschmann plug connection

Device with EP-tronic with Hirschmann plug connection

Connection diagram see chapter 7.2.7

for function see chapter 11.2

Signal indicators see chapter 15.3.2

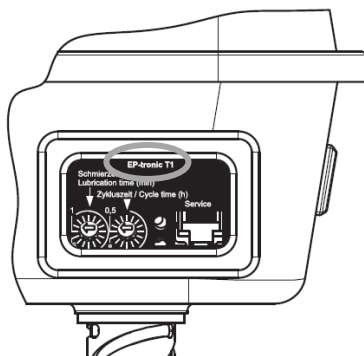

EP-tronic T1 in the viewing window with bayonet plug connection

Device with EP-tronic T1 with bayonet plug connection

Connection diagram see chapter 7.2.8

for function see chapter 11.3

Signal indicators see chapter 15.3.3

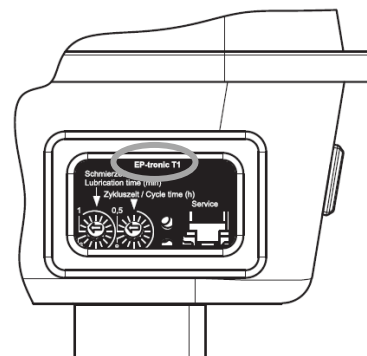

EP-tronic T1 in the viewing window with Hirschmann plug connection

Device with EP-tronic T1 with Hirschmann plug connection

Connection diagram see chapter 7.2.9

for function see chapter 11.3

Signal indicators see chapter 15.3.3



EP-T2 in viewing window with bayonet plug connection

Device with EP-T2

Connection diagram see chapter 7.2.10

for function see chapter 11.4

10177337

BAL_EP-1_FKGGM-EP_1221DE_EN_FR_IT_ES

2. Further applicable documents

Dimensioned drawing AZ...
 Connection diagram ES...
 Spare parts drawing ET...
 Declaration of incorporation

3. General safety instructions

Before assembly and commissioning the device on the machine, these operating instructions must be read carefully by all persons entrusted with the assembly, commissioning, maintenance and operation of the device! It also must be available at the site of use at all times.

Below, basic notes are given that must be observed during operation and maintenance.

3.1 Safety instructions

Observe both the general safety instructions in this main chapter and the special safety instructions in other chapters of these operating and assembly instructions.



Warnings of electrical voltage with this symbol.



Safety instructions which may cause danger to persons if not observed are marked with the general danger symbol.



Warnings about hot surfaces with this symbol.



Warning of suspended loads with this symbol.



Warning of material damage due to electrostatic discharge! Indicates a potential danger that could result in property damage if not avoided.

Attention!

This heading is used when imprecise observance or non-observance of the operating instructions, work instructions, prescribed work sequences and the like can lead to damage to the device.

Note!

If attention is to be drawn to special features, this expression is used.

Notes attached directly to the device must be observed and kept in a completely legible condition!

3.2 Personnel qualification and personnel training



The personnel for operation, maintenance, inspection and installation must have the corresponding qualification for this work. Relevance, responsibility and monitoring of personnel must be provided for precisely by the operator. If the personnel do not have the required knowledge, they must be trained and instructed. The operator must ensure that the content of the user information is understood in full by the personnel.

3.3 Dangers at non-observance of the safety instructions



Danger to persons, the environment and the machine may result from **non-observance** of the **safety instructions**. Non-observance of the safety instructions may cause loss of any damages claims. Specifically, non-observation may, e.g., cause the following dangers:

- Failure of important functions of the device.
- Failure of prescribed methods for maintenance and servicing.
- Danger to persons from electrical, mechanical and chemical effects.
- Danger to the environment from leakage of hazardous substances.

3.4 Obligations of the operator / users



- Where moving, rotating, hot or cold device parts cause any dangers, they must be secured against contact on site. This contact protection must not be removed.
- Leaks of dangerous conveyed media must be discharged so that no danger to persons and the environment will result. The data sheets or safety data sheets of the respective manufacturers must also be observed.
- Statutory provisions must be complied with.
- Dangers from electrical energy must be excluded.
- The inspections for pipe or hose assemblies for safe provision, use, proper assembly and function are to be carried out in accordance with regionally applicable guidelines. The inspection intervals must not be exceeded.
- Defective pipe or hose lines must be replaced immediately and professionally.
- Hydraulic hose lines and poly pipes are subject to an ageing process and must be replaced at regular intervals in accordance with the manufacturer's specifications.
- A safety data sheet of the lubricant currently used must be made available at the device.
- Observe the latest version of the generally applicable hazardous substances ordinance.

3.5 Safety instructions for maintenance, inspection and assembly work



All **maintenance, inspection** and **assembly work** must only be performed by **authorised and qualified specialists** who have collected enough information by studying the user information thoroughly.

As a matter of principle, work on the device may only be carried out **when it is at a complete standstill** and in a **depressurised and de-energised state**, with appropriate **personal protective equipment** (including safety goggles). The procedure described in these operating instructions for shut-down of the device must be complied with.

Secure the device during maintenance and repair work against intentional and unintentional restarting. All safety and protection devices must be inserted again at once after the work is completed.

According to the relevant authority provisions, any environmentally hazardous media must be disposed of professionally. **Dirty** or **contaminated surfaces** must be **cleaned** before maintenance work, protective equipment must be worn for this purpose. Observe the data and safety data sheets of the lubricant manufacturers or those of the manufacturers of the auxiliary and operating materials used.



The surface temperature of the device must be checked, as there is a **risk of burns** due to heat transfer. Wear heat-resistant safety gloves!

During all maintenance, inspection and repair work, **open light** and **fire** are **strictly prohibited** due to **fire hazard**.

3.6 Independent conversion and spare parts production



Conversion, repair and changes to the device are only permitted in coordination with the manufacturer. **Genuine spare parts** and accessories authorised by the manufacturer are used for **safety purposes**. Use of other parts may revoke liability for resulting consequences. Groeneveld-BEKA accepts no liability for components retrofitted by the operator.

3.7 Inadmissible operating modes

The operating safety of the device is only ensured at intended use as indicated in the operating instructions. The thresholds indicated in the technical documents must never be exceeded or undercut.

3.8 Electrostatic discharge



Avoid electrostatic discharge! The devices contain electronic components that can be destroyed by electrostatic discharge when touched. Observe the safety measures against electrostatic discharge according to DIN EN 61340-5-1/-3. When handling the devices, ensure that the environment (people, workplace and packaging) is well grounded.

3.9 General danger warning - residual risk



All components of the device are designed in accordance with the applicable regulations for the construction of technical systems with regard to operational safety and accident prevention. Irrespective of this, their use can lead to dangers for the user or third parties or other technical equipment. The device may therefore only be used for its intended purpose if it is in a **technically fault-free condition**. This may only be done in compliance with the relevant safety regulations and by observing the operating instructions. Therefore, **regularly observe** the device and its attachments and check them for any **damage or leaks**. **Fluid can escape under high pressure** from pressurised system parts that have become **leaky**.

4. Intended use

Attention!

The device is used as part of a central lubrication system **for conveying lubricant for the lubrication of machines** as described in these operating instructions. The device is approved for **industrial and commercial use only**.

The device may only be put into operation if it is installed in / attached to another machine and operated together with it.

Only lubricant in accordance with the machine manufacturer's specifications may be conveyed.

The device may only be used in accordance with the technical data (see chapter 1 "Technical data"). These values must not be exceeded or undercut under any circumstances. Never operate the device without lubricant.

Unauthorised **structural changes** to the device are **not permitted**. Groeneveld-BEKA accepts no liability whatsoever for any resulting damage to persons or machinery.

The device was manufactured in compliance with the machinery directive 2006/42/EC. The customer must check whether further guidelines apply for the area of application and place of use. If the device does not conform to these guidelines, it must not be put into operation.

Intended use also includes:

- That you observe all chapters and notes in the operating instructions.
- That you perform all maintenance work.
- That you **comply with** all relevant regulations on **occupational safety** and **accident prevention** during all life cycles of the device.
- That you have the required professional training and authorisation from your company to perform the required work on the equipment.

Any other use or use in excess thereof shall be deemed to be an unauthorised mode of operation.

5. Scope of warranty

Warranties with regard to operational safety, reliability and performance are only warranted by the manufacturer if the product is used as intended and only under the following conditions:

- Assembly, connection and maintenance are carried out by authorised specialist personnel.
- The device is used as described in the operating instructions.
- The thresholds indicated in the technical data must never be exceeded.
- Modification and repair work on the device may only be carried out by Groeneveld-BEKA.

For damage caused to the device by operation with unsuitable lubricant (e.g. piston wear, piston jamming, blockages, embrittlement of seals, etc.), the warranty and guarantee are void.

Attention!

Groeneveld-BEKA generally does not accept any warranty for damage caused by lubricants, even if these have been subjected to a laboratory test at Groeneveld-BEKA and have been approved, as damage caused by lubricants (e.g. due to overstocked, incorrectly stored lubricants, batch fluctuations, etc.) cannot be traced in retrospect.

6. Transport and storage

Use suitable lifting devices for transport.

Do **not throw the device** or subject it to strong impacts.

The device must be secured against falling over or slipping during transport.

The device may only be transported when completely empty.



Observe the applicable safety and accident prevention regulations during transport. Wear **appropriate protective equipment** if necessary! Keep **sufficient distance to suspended loads**. The means of transport or the lifting device must have **sufficient load-bearing capacity**.

Note!

When storing the device, the storage location should be cool and dry so as not to support corrosion of individual parts of the device.

Observe the storage life of the lubricant contained in devices filled with lubricant. Replace the lubricant if it is overstocked (separation of oil and soap).

Store the device in an **upright position** (reservoir standing vertically upwards, see fig. 3).

Fig. 3:

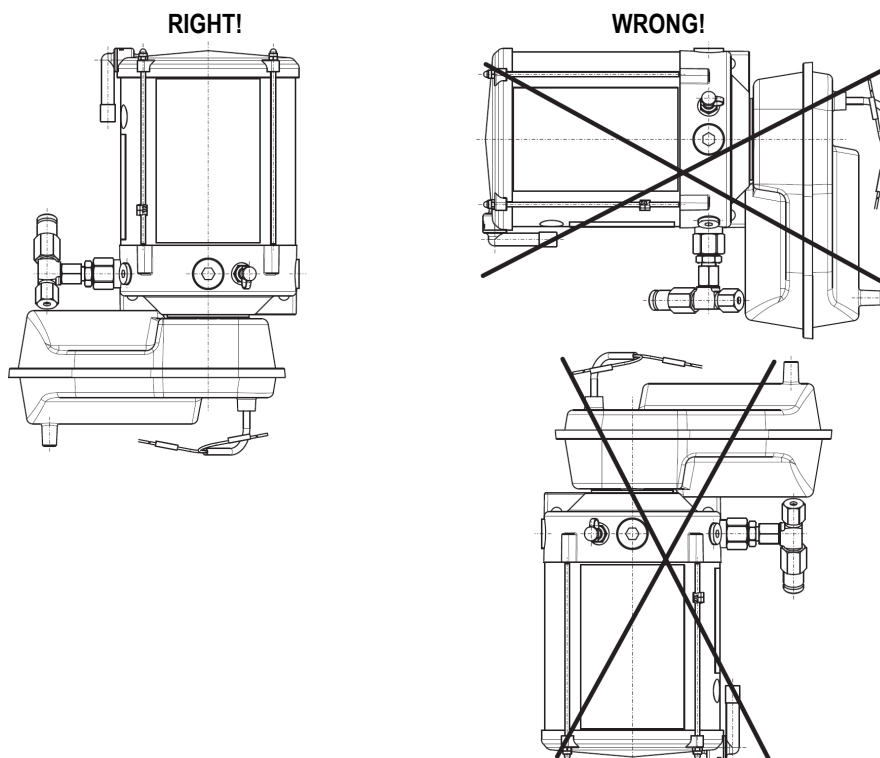

7. Assembly instructions

The device must be completely checked for any transport damage and for completeness before assembly! Any transport locks attached must be removed.



When assembling this device, the following conditions must be met so that it can be properly assembled with other parts to form a complete machine in an environmentally friendly manner without compromising the safety and health of persons:

At the place of installation, assemble the device on both sides balanced with the **reservoir facing upwards** to ensure safe operation! Please also note the data on the mounting holes given in the dimensional drawing. When selecting the attachment points, the device should be protected against ambience and mechanical influences if possible. Unhindered access, for example for lubricant filling, must be ensured.

Special measures for noise protection and vibration reduction of the device at assembly and installation are not necessary.

7.1 Line assembly

- Professional design!
- When using piping, only use cleaned, seamless precision steel pipes!
- Install the pipeline correctly and without tension!
- Observe the pressure tightness of the screw connections!
- All components must be approved for the maximum operating pressure (see technical data).

7.2 Electrical connection



- Electrical power supply may only be established by a trained electrician!
- The electrical components of the device must be wired properly!
- Compare voltage specifications with existing mains voltage!
- The potential equalisation must be carried out professionally by the user via an appropriate ground connection!
- Wire the device according to the electrical connection diagram!

Note!

The connection diagrams listed below are valid for standard versions. Other connection diagrams may apply to special versions. You will receive these on request.

Attention!

Before connecting the device, check whether it is a **special version!** Incorrect connection can lead to the **destruction of the device!**

7.2.1 Connection diagram for devices in version without control unit, without plug connection

Fig. 4:

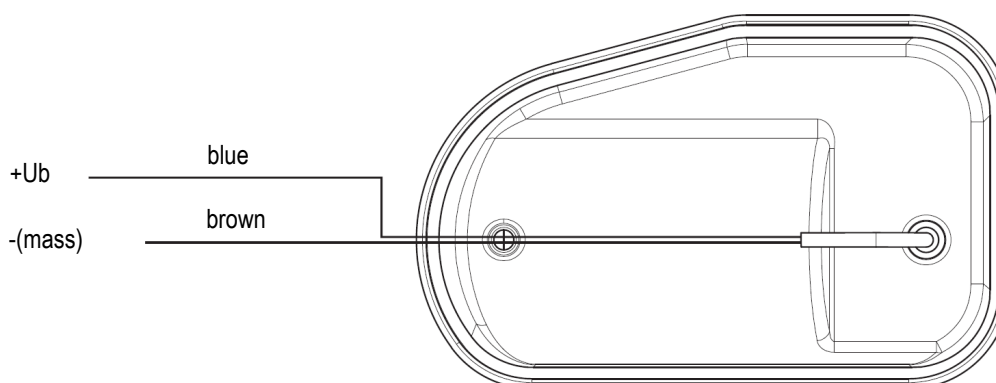

10177337

BAL_EP-1_FKGGM-EP_1221DE_EN_FR_IT_ES

7.2.2 Connection diagram for devices in DC version without control unit, with bayonet plug connection

Fig. 5:

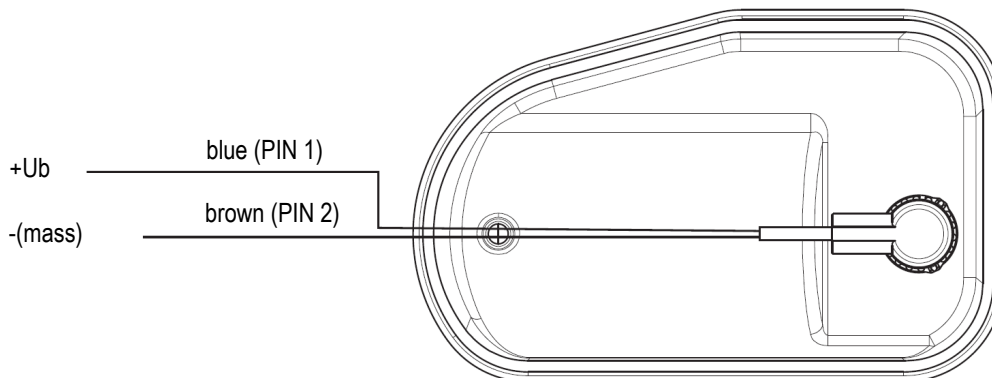

Note!

For devices in DC version without control unit, with bayonet plug connection, the **connection plug** and a **10 m long connection cable** are included in the **scope of delivery**.

7.2.3 Connection diagram for devices in AC version without control unit, with Hirschmann plug connection

Fig. 6:

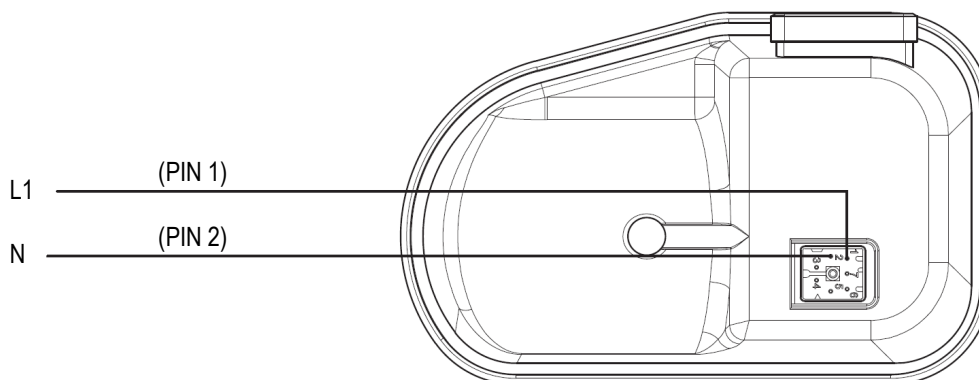

Note!

For devices in AC version without control unit, with Hirschmann plug connection, the **connection plug** is included in the **scope of delivery**. A connection cable must be ordered separately.

Attention!

For **devices in AC version**, always pay attention to the **voltage (115 V or 230 V)**, which can be seen in the viewing window of the protective housing (see chapter 1.2 "Version of the device", fig. 1).

10177337

BAL_EP-1_FKGGM-EP_1221DE_EN_FR_IT_ES

7.2.4 Connection diagram for devices with BEKA-troniX1 with bayonet plug connection

Fig. 7:

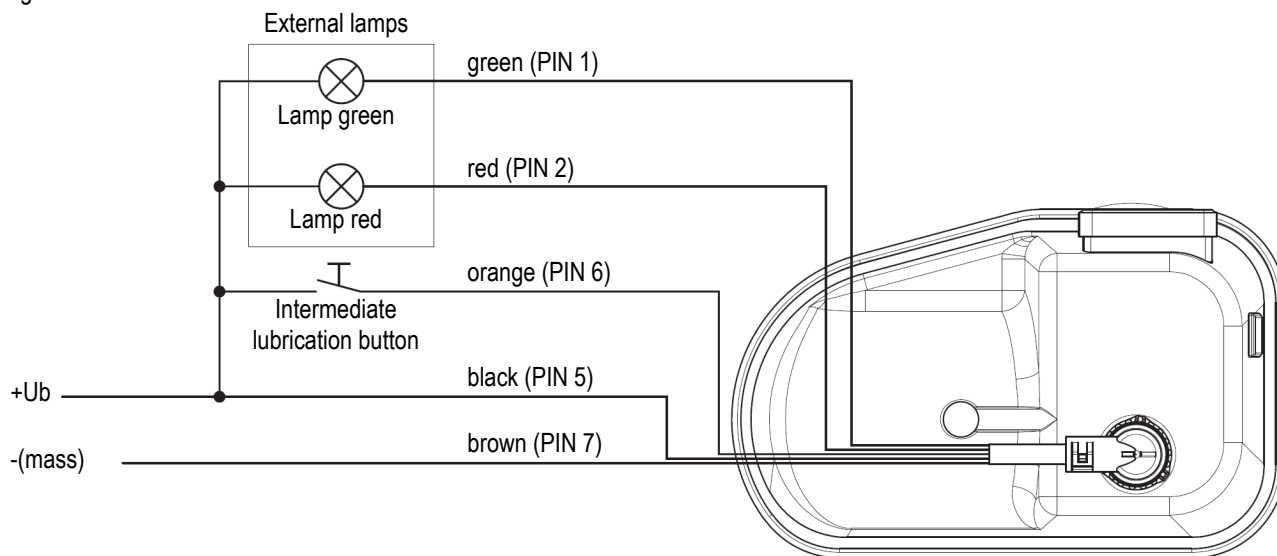

(PIN ...) = Assignment of the cable socket

Note! For devices with BEKA-troniX1 the **bayonet connection plug** and a **10 m long connection cable** are always included in the **scope of delivery**.

7.2.5 Connection diagram for devices with BEKA-troniX1 with bayonet plug connection and plug connections M12x1

Fig. 8:

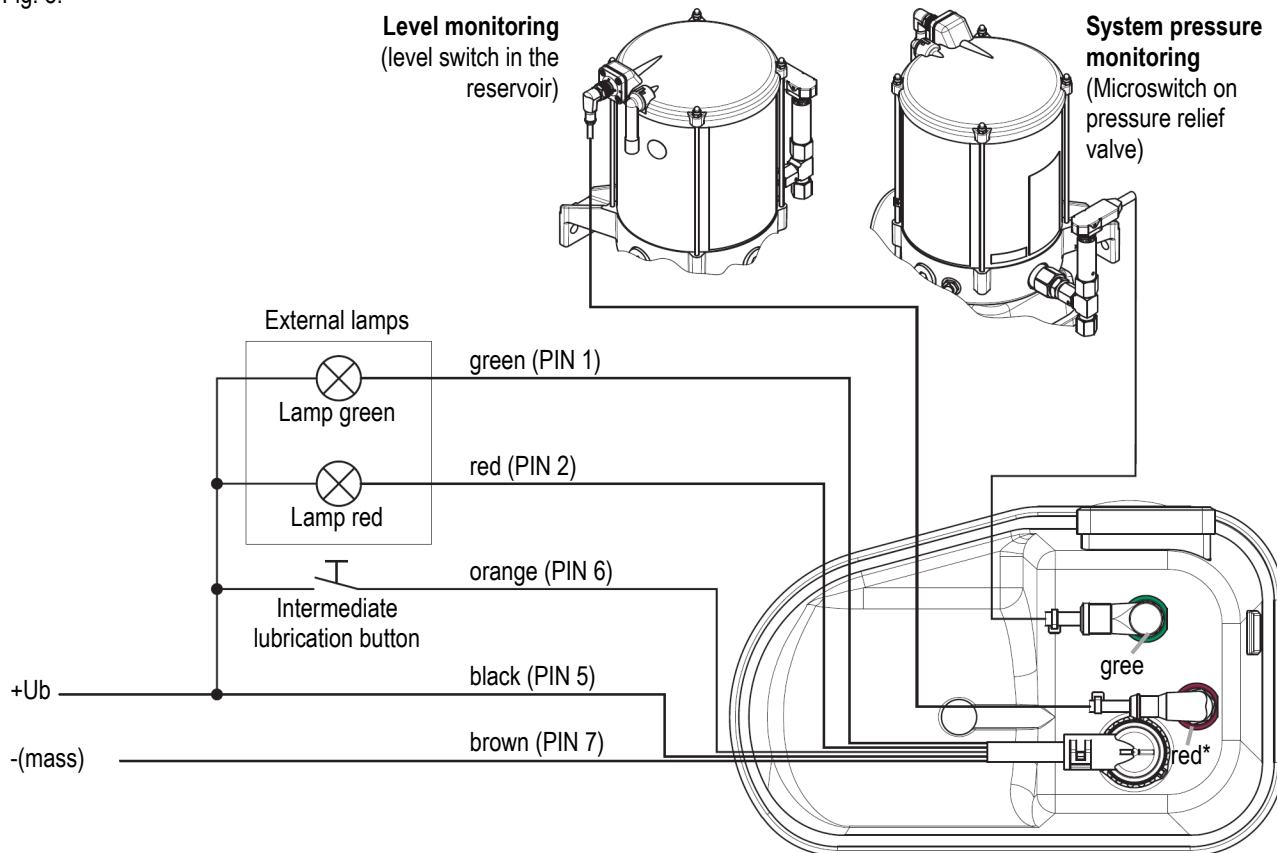

(PIN ...) = Assignment of the cable socket

* only for version with plug connections M12x1 (see chapter 11.1 "BEKA-troniX1" and chapter 16.4 "Code for devices EP-1 with BEKA-troniX1")

For devices with BEKA-troniX1 the **bayonet connection plug** and a **10 m long connection cable** are always included in the **scope of delivery**.

Note!

The **connection plug M12x1** and a **5 m long connection cable** for the **level monitoring** function are included in the **scope of delivery** if the device is equipped with a level monitoring function.

All other connection plugs and connection cables are not included in the scope of delivery and must be ordered separately.

10177337

BAL_EP-1_FKGGM-EP_1221DE_EN_FR_IT_ES

7.2.6 Connection diagram for devices with EP-tronic with bayonet plug connection

Fig. 9:

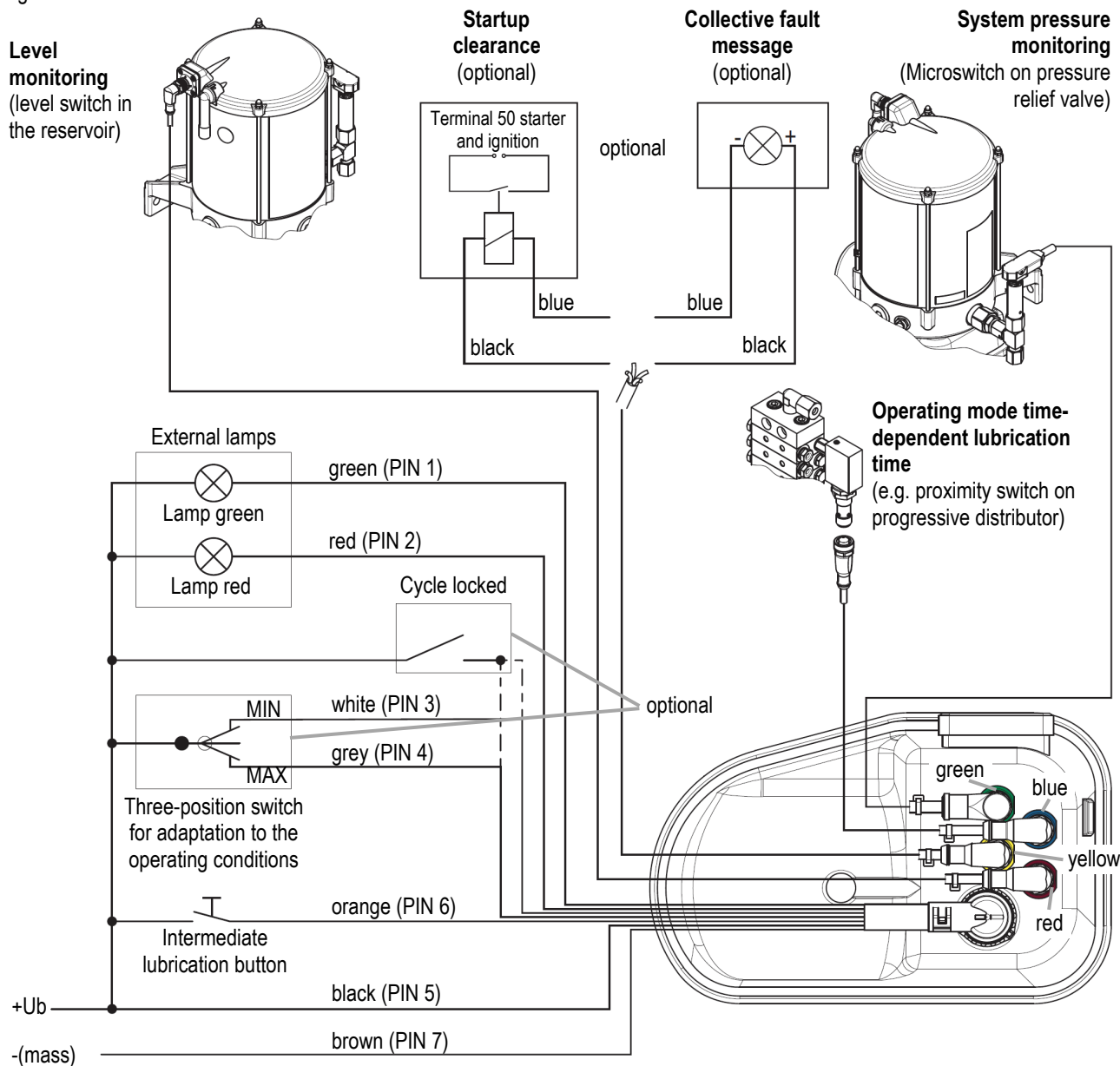

(PIN ...) = Assignment of the cable socket

Note!

For devices with EP-tronic with bayonet plug connection, the **bayonet connection plug** and a **10 m long connection cable** are **always** included in the **scope of delivery**.
 The **connection plug M12x1** and a **0.6 m long connection cable** for the **level monitoring** function are included in the **scope of delivery** if the device is equipped with a level monitoring function.
 All other connection plugs and connection cables are not included in the scope of delivery and must be ordered separately.

10177337

BAL_EP-1_FKGGM-EP_1221DE_EN_FR_IT_ES

7.2.7 Connection diagram for devices with EP-tronic with Hirschmann plug connection

Fig. 10:

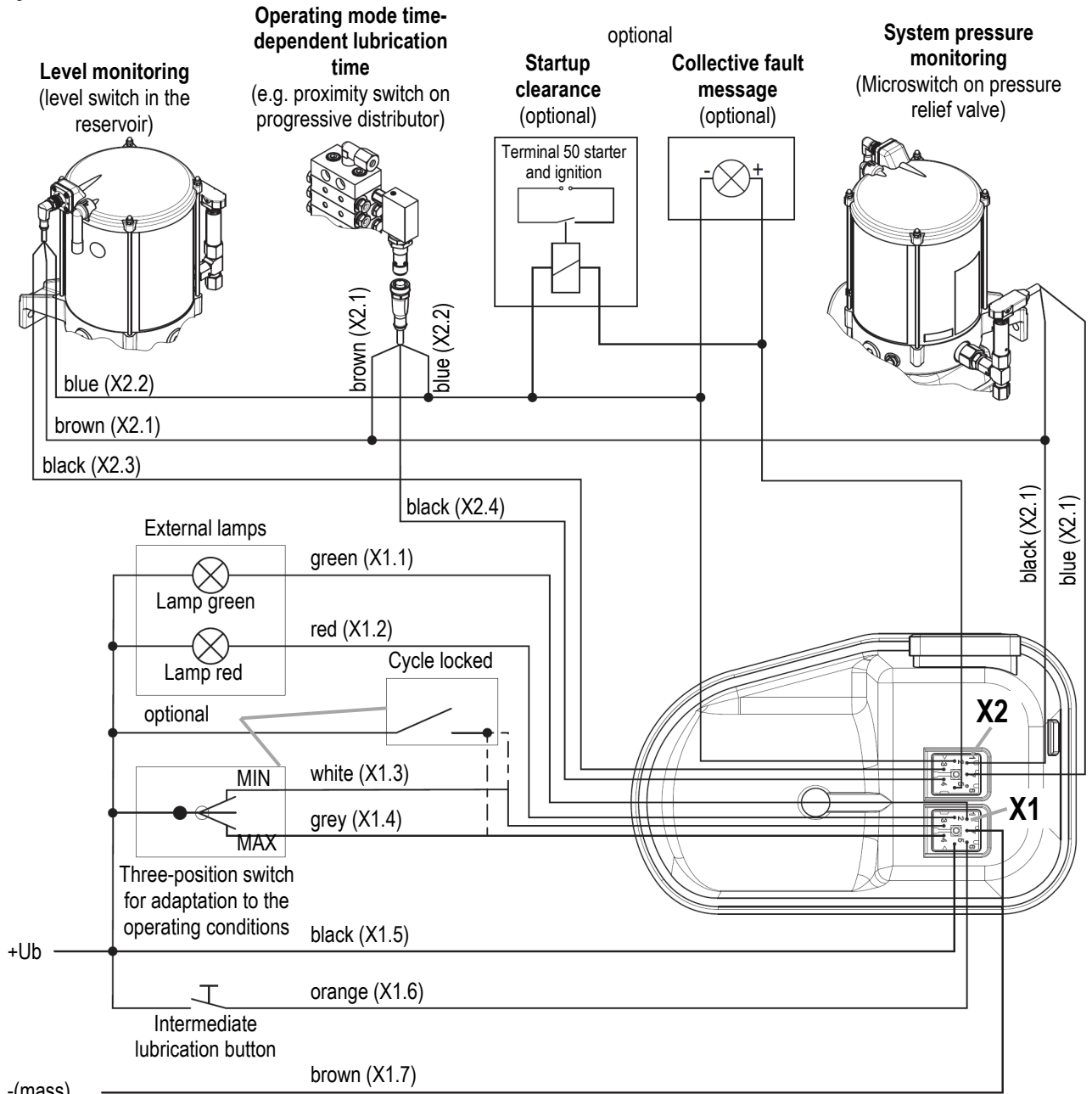

(PIN ...) = Assignment of the cable socket

Note!

For devices with EP-tronic with Hirschmann plug connection, the **Hirschmann plug connection for the power supply** and a **10 m long connection cable** are **always** included in the **scope of delivery**. The **Hirschmann plug connection for the special functions** is also included in the **scope of delivery**, but the corresponding **connection cable** must be **ordered separately**.

10177337

BAL_EP-1_FKGGM-EP_1221DE_EN_FR_IT_ES

7.2.8 Connection diagram for devices with EP-tronic T1 with bayonet plug connection

Fig. 11:

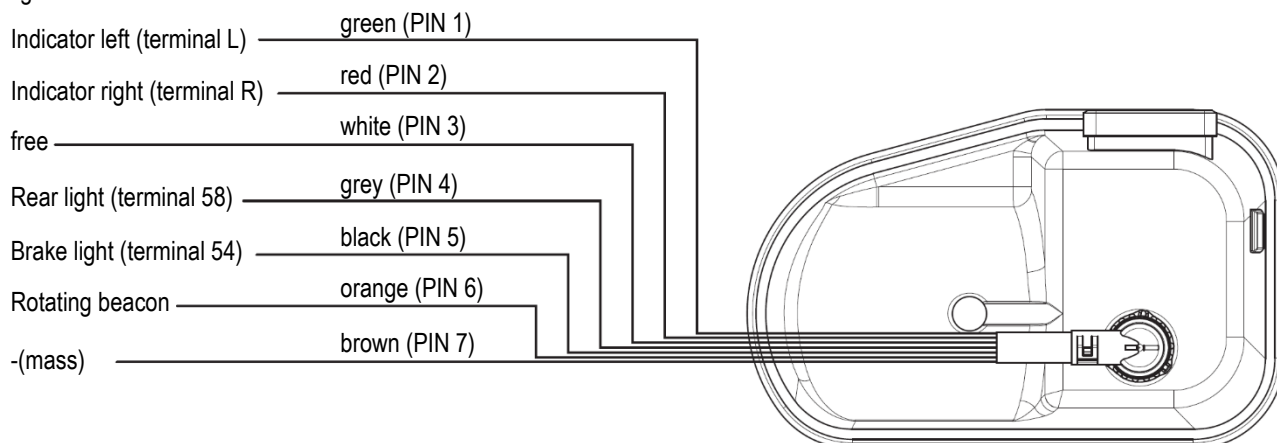

(PIN ...) = Assignment of the cable socket

Note!

For devices with EP-tronic T1 with bayonet plug connection, the **connection plug** and a **10 m long connection cable** are always included in the **scope of delivery**.

7.2.9 Connection diagram for devices with EP-tronic T1 with Hirschmann plug connection

Fig. 12:

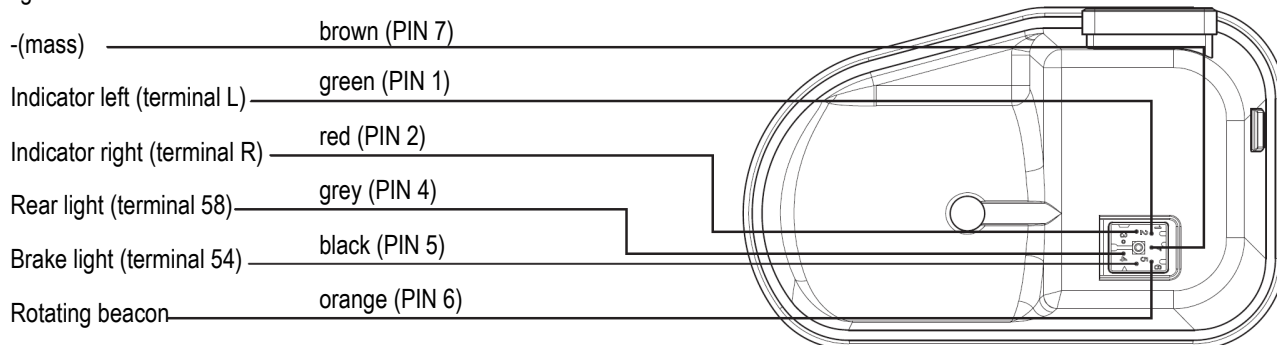

(PIN ...) = Assignment of the cable socket

Note!

For devices with EP-tronic T1 with Hirschmann plug connection, the **connection plug** and a **10 m long connection cable** are always included in the **scope of delivery**.

7.2.10 Connection diagram for devices with EP-T2

Fig. 13:

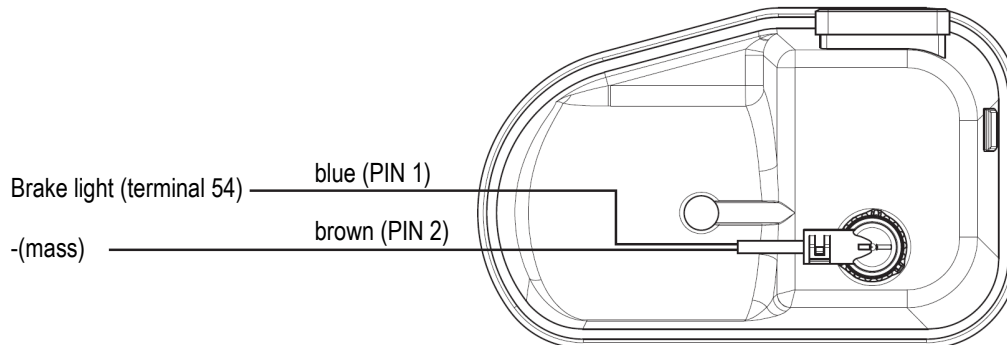

(PIN ...) = Assignment of the cable socket

Note!

For devices with EP-T2, the **connection plug** and a **10 m connection cable** are always included in the **scope of delivery**.

10177337

BAL_EP-1_FKGGM-EP_1221DE_EN_FR_IT_ES

7.2.11 Connection diagram for level monitoring with cable socket EN 175301-803A

Fig. 14:

10 - 60 V DC (standard) 90 - 250 V AC

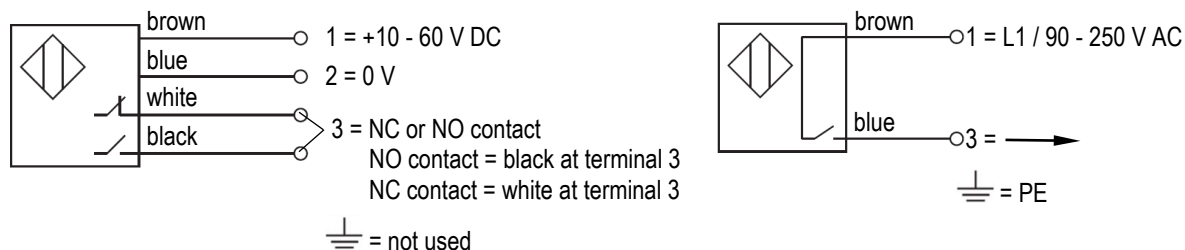
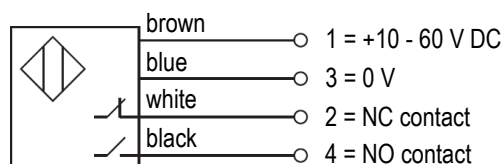
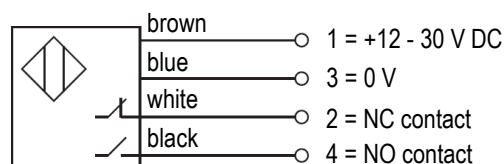

Fig. 15:

10 - 60 V DC (standard)



10 - 30 V DC (low temperature version)



Different pump elements can be installed in the device at three positions (see chapter 9.4 "Pump elements").

Fig. 16:

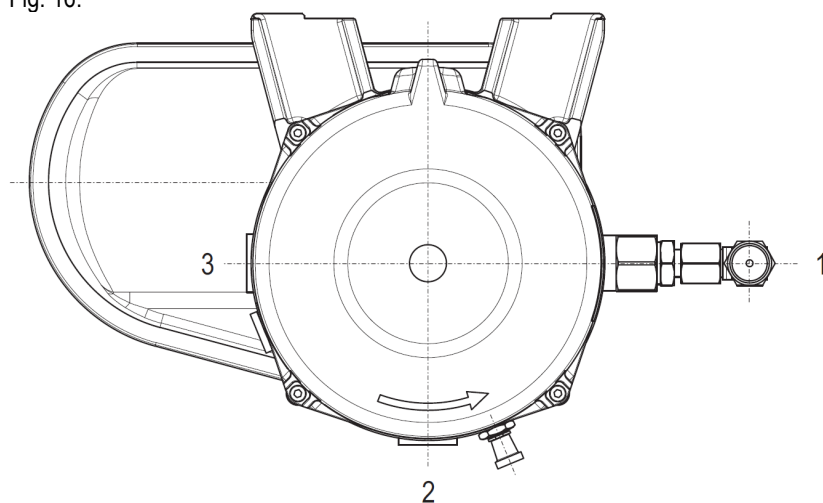

Pump elements PE-60, PE-120, PE-170 or PE-120 V can be screwed into each of the outlets.

Change the seal of the pump element to avoid reuse of damaged seals.

The following describes the removal and installation of the pump elements using the PE-120 as an example.

7.3.1 Removal of a pump element

- A) Disconnect the device from the electrical power supply (pos. 1, see fig. 16) and secure it against restarting.
- B) Unscrew the pump element a little and tilt it slightly downwards (see fig. 17).

Fig. 17:

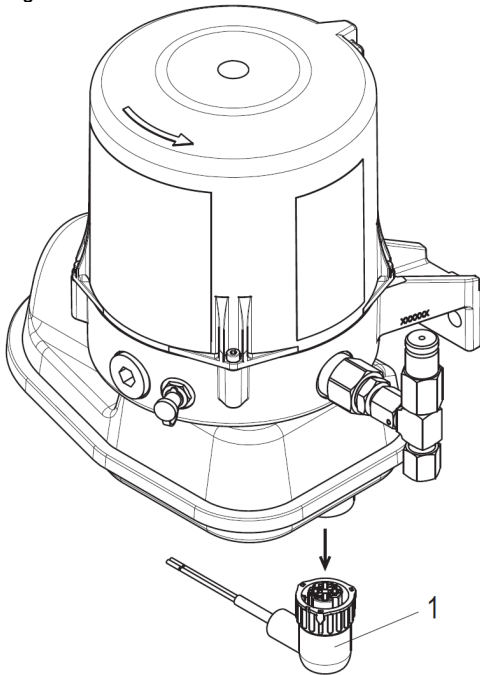
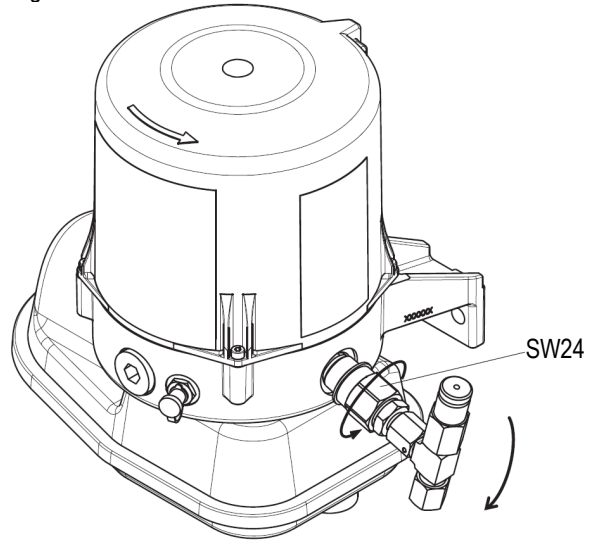

Fig. 18:



Attention!

Make sure that the piston of the pump element (pos. 2, see fig. 18) does **not remain** in the pump housing! Leaving the piston in the pump housing can cause damage to the device and its components!

Fig. 19:

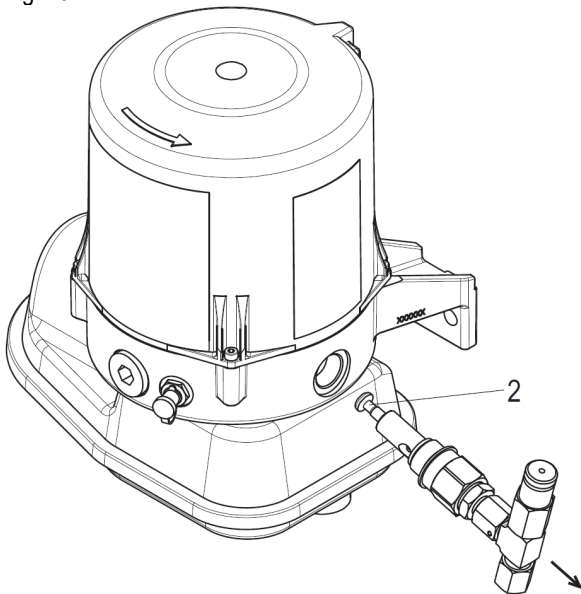

7.3.2 Installation of a pump element

Attention!

- D) Insert the pump element with new seal and with the piston partly pulled out (pos. 2, see fig. 20) diagonally upwards into the outlet in the pump housing.

10177337

BAL_EP-1_FKGGM-EP_1221DE_EN_FR_IT_ES

Fig. 20:

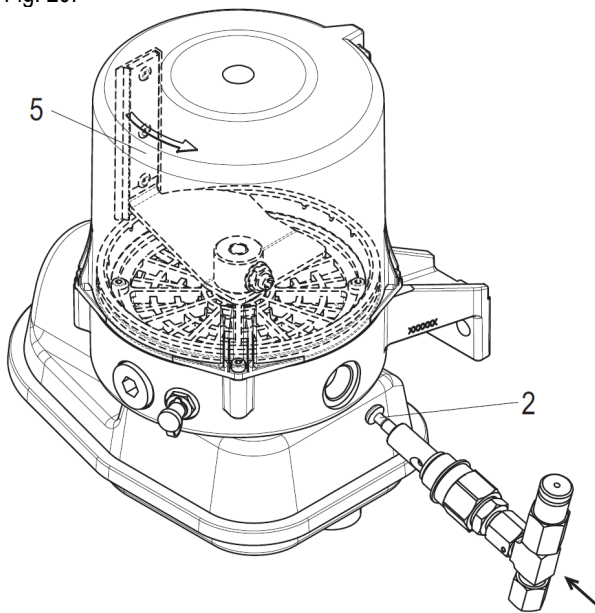
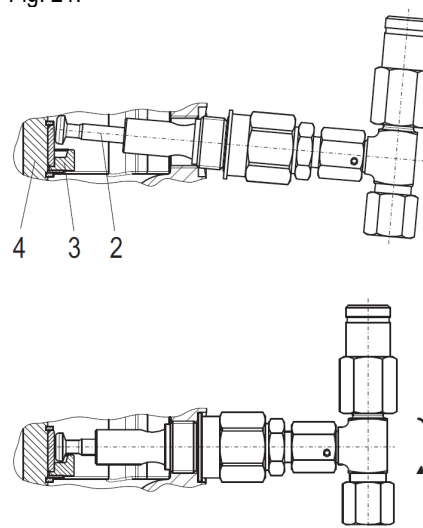

Fig. 21:



- E) The piston of the pump element (pos. 2, see fig. 21) must be hooked into the eccentric ring (pos. 3, see fig. 21). Bring the pump element into a horizontal position when the piston head is in contact with the eccentric (pos. 4, see fig. 21).
- F) Align the pump element until the desired position is reached and screw it in by hand until it stops. Then tighten it with a torque of $45 \text{ Nm} \pm 10\%$ (see fig. 22)

Attention!

Loosen the pump element completely once again and insert it into the outlet again as described under point D.

Fig. 23:

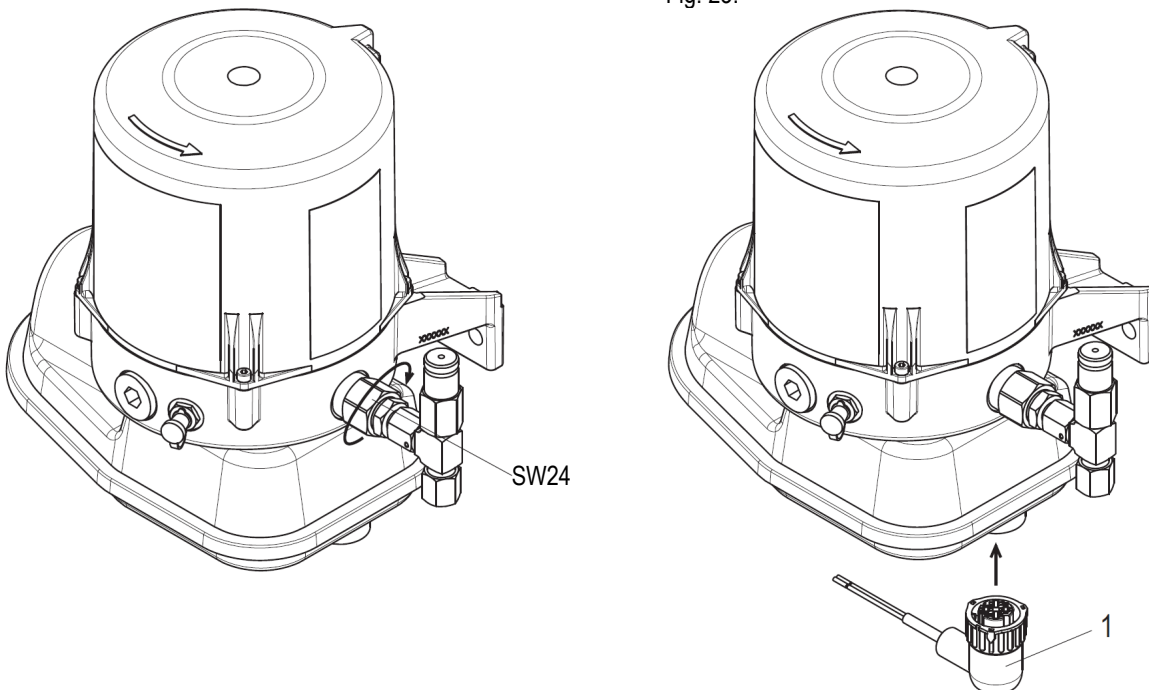

- G) Reconnect the device to the electrical power supply (pos. 1, see fig. 23). Start a test run and run the device with the outlets open until the lubricant comes out free of air bubbles.

10177337

BAL_EP-1_FKGM-EP_1221DE_EN_FR_IT_ES

8. Commissioning

8.1 Lubricants

The device is designed for commercially available multi-purpose greases up to NLGI class 2.

- Use lubricants with high pressure additives.
- Only use lubricants of the same saponification type.
- Do not use lubricants with solid content (lubricants with solid content on request, such as graphite or MoS₂).

8.2 Lubricant filling

- Fill the reservoir with clean lubricant via the filler cap (if present), via the conical lubrication nipple (see chapter 8.2.1), via a filling connection and a filling pump (see chapter 8.2.2) or a filling connection and a filling press (see chapter 8.2.3).

Note!

Air can be trapped in the lubricant during lubricant filling. This can be avoided by having the device conveying lubricant during the filling process. To do this, switch on the device.

- Observe the lubricant specifications of the machine manufacturer! Only use lubricants according to the machine manufacturer's specifications!
- Collect leaking lubricant in a suitable reservoir and dispose of properly!
- Observe the safety data sheet of the lubricant manufacturer!
- The flow behaviour of the lubricant changes with the operating temperature!
- Check the level several times at equal intervals during the first operating hours, top up with clean lubricant if necessary!
- Pay attention to extreme cleanliness during the lubricant filling process!

Attention!

If dirt particles get into the device, the pistons of the pump elements may wear out, resulting in destruction of the pump elements. In addition, dirt particles can get into the lubrication system and clog lines or connected progressive distributors.

Avoid overfilling the device!

8.2.1 Filling via conical lubrication nipple with filling press (standard)

- A) Remove the protective cap from the existing conical lubrication nipple.
- B) Connect a suitable filling press (manually operated or pneumatic) to the conical lubrication nipple.
- C) Fill the device to the maximum level (see fig. 24).
- D) After finishing the filling process, put the protective cap back on the conical lubrication nipple.

Fig. 24:

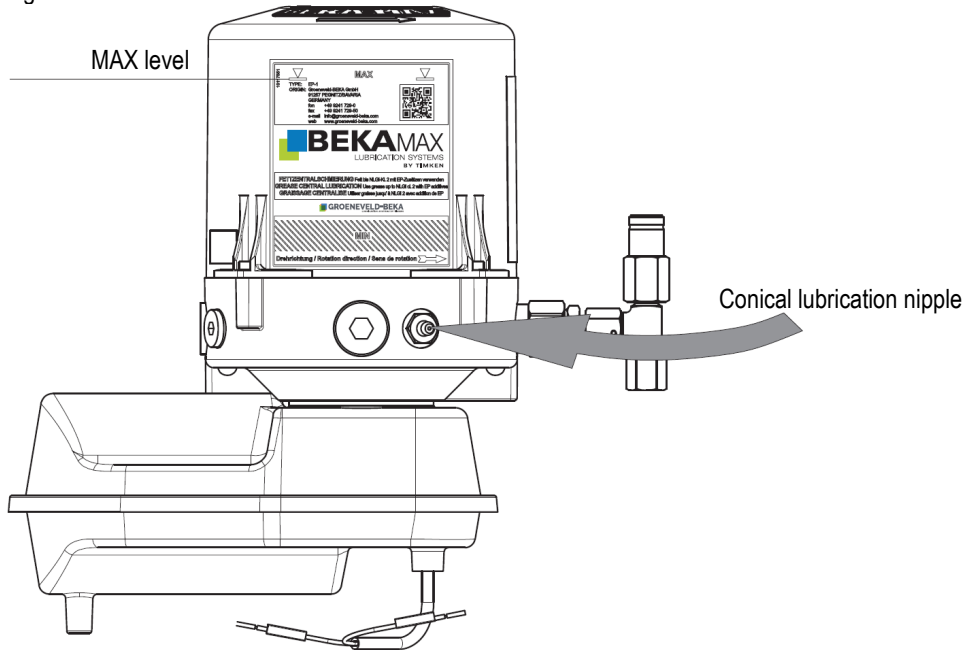

8.2.2 Filling via filling connection and filling pump

- A) Remove the conical lubrication nipple and replace it with a G1/4 filling connection (part no.: 10125524). Or remove the screw plug from the outlet 2 (see fig. 16 in chapter 7.3 "Assembly of the pump elements") and screw in a filling connection M20x1.5 (part no.: 10112822).
- B) Connect a suitable filling pump to the filling connection G1/4 or M20x1.5.
- C) Fill the device to the maximum level (see fig. 25).

Fig. 25:

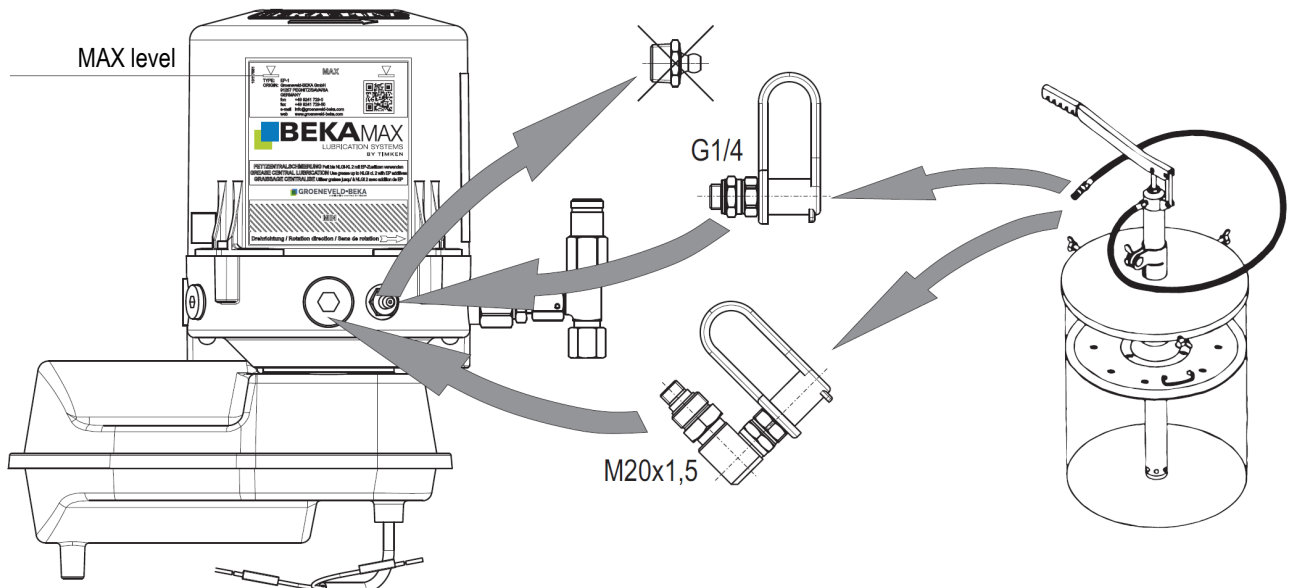

10177337

BAL_EP-1_FKGGM-EP_1221DE_EN_FR_IT_ES

8.2.3 Filling via filling connection and manual grease gun

- A) Remove the screw plug from the outlet 2 (see fig. 16 in chapter 7.3 "Assembly of the pump elements").
- B) Screw a filling connection M20x1.5 (part no.: 10104288) in the outlet 2.
- C) Operate the manual grease gun (part no.: 10125287) until the lubricant visibly emerges at the outlet (approx. 10 mm, see fig. 26).
- D) Connect the filling press to the filling connection.
- E) Fill the device to the maximum level.

Fig. 26:

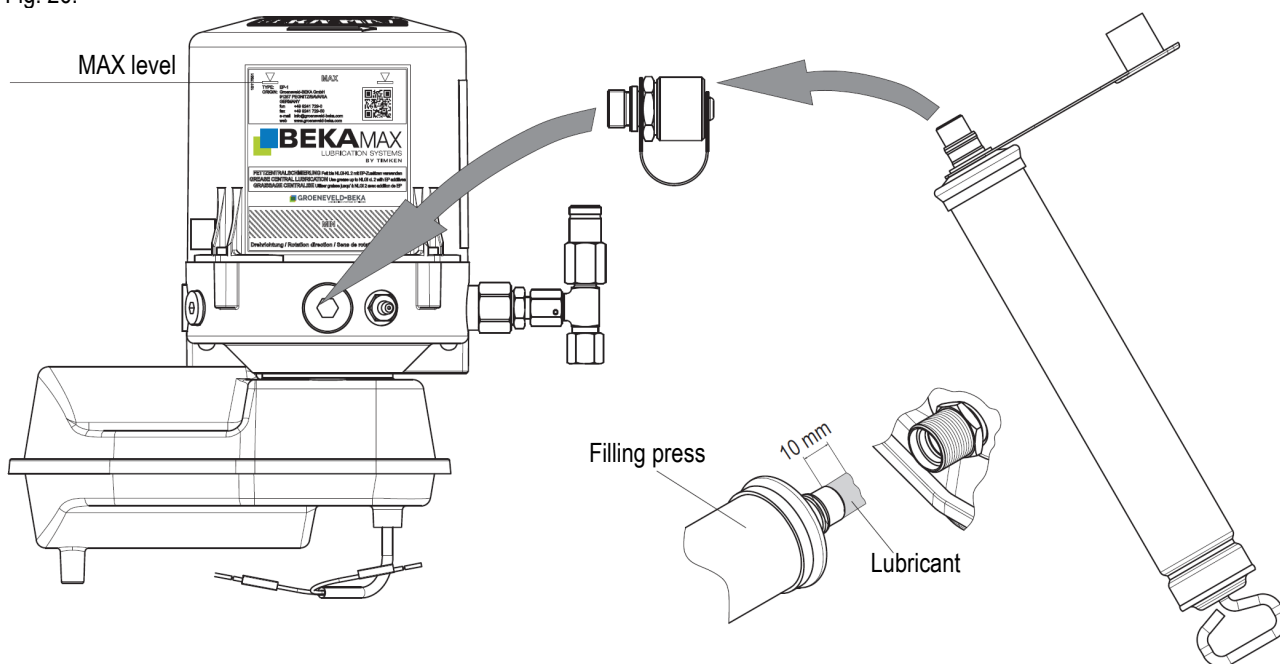

8.3 Checking the direction of rotation of the device

- Compare the direction of rotation of the agitator blade with the direction of rotation arrow on the level sticker (see fig. 27).
- If the direction of rotation is incorrect, check the electrical connections of the device and change them if necessary (see chapter 7.2 "Electrical connection")

Attention!

Prolonged running in the **wrong direction of rotation** leads to **motor damage** and **damage to the device!**

Fig. 27:

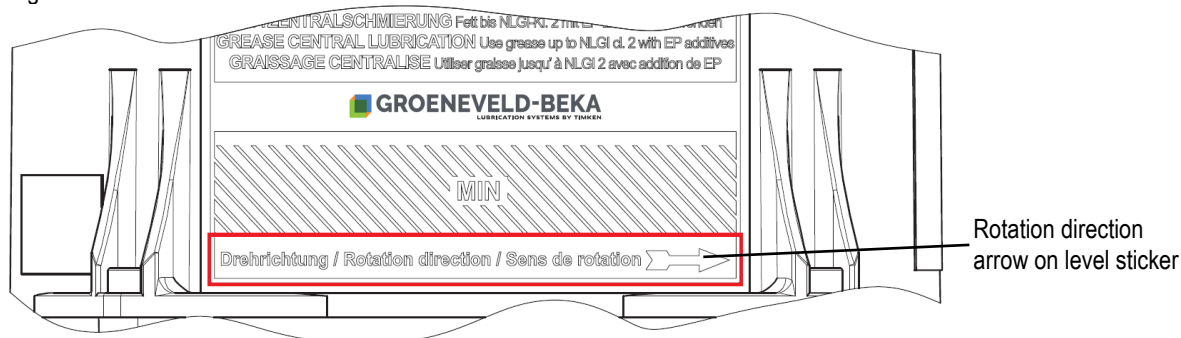

8.4 Venting of the lubrication system

- Vent the complete lubrication system during initial commissioning and after each lubricant change!
- Venting takes place by pressureless operation with the outlets of the system open!
- For venting, operate the device until the lubricant emerges from the pressure connection free of air bubbles!

9. Function description

9.1 General

The device can be used for lubrication in progressive lubrication systems. The lubrication systems can be controlled simultaneously by an optionally installed control unit.

When installed in a progressive lubrication system, up to three independent lubrication circuits can be connected to the device.

Progressive lubrication systems are lubrication systems that can process lubricants up to NLGI class 2.

A progressive lubrication system consists mainly of a lubrication pump and one or more progressive distributors. The lubrication pump conveys the lubricant to a main distributor. This distributes the lubricant in the specified ratio to the sub-distributors, which further distribute the lubricant to the lubrication points.

If a lubrication point does not take lubricant from the progressive distributor, the distributor blocks and pressure builds up in the system. The system pressure is limited to 290 bar by a pressure relief valve on the pump element (pos. 4, see fig. 28). This protects the system from damage due to excessive pressure.

Fig. 28:

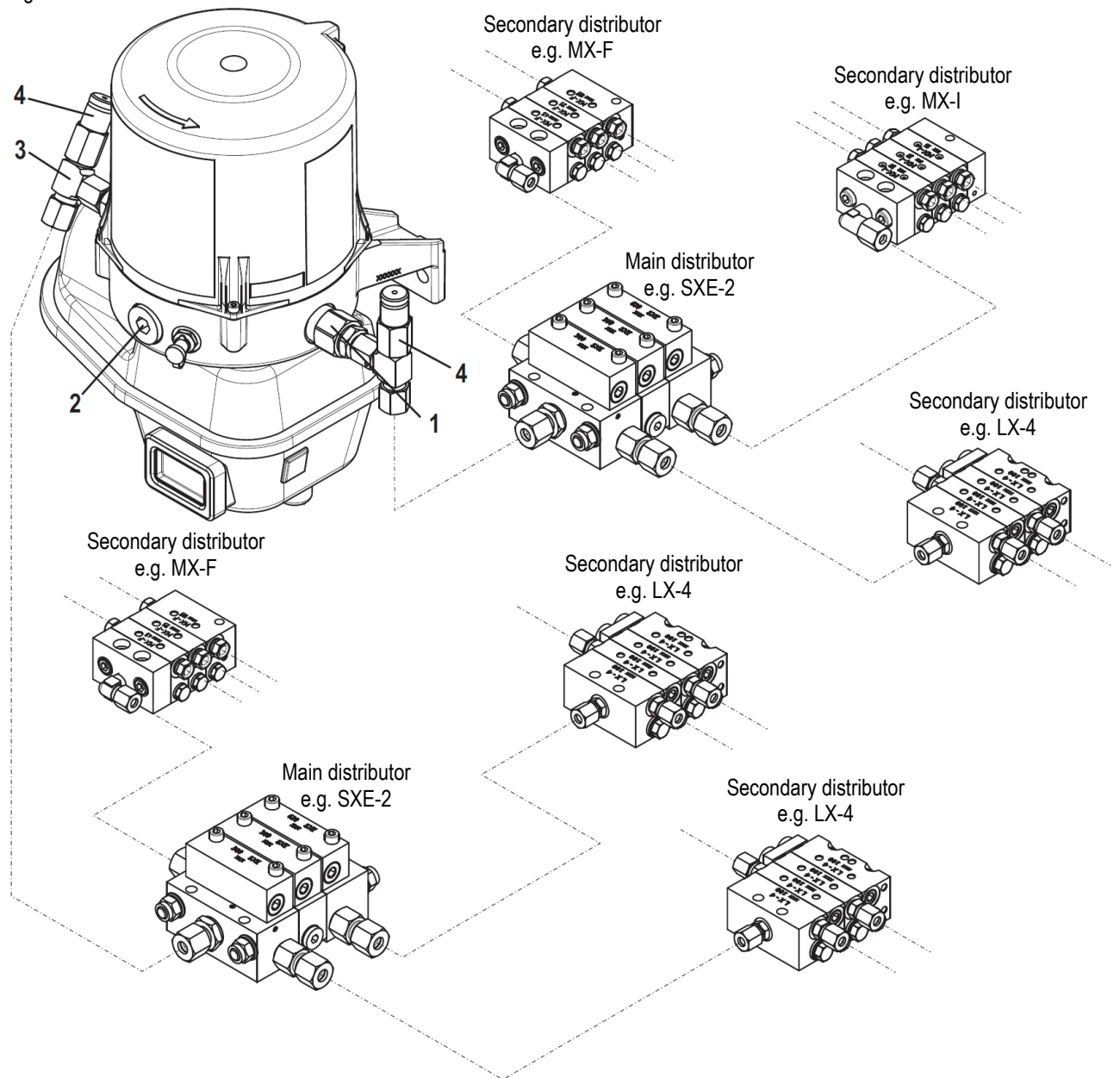

10177337

BAL_EP-1_FKGGM-EP_1221DE_EN_FR_IT_ES

9.2 Structure of the device

The device mainly consists of 6 assemblies (see fig. 29 and fig. 30).

Fig. 29:

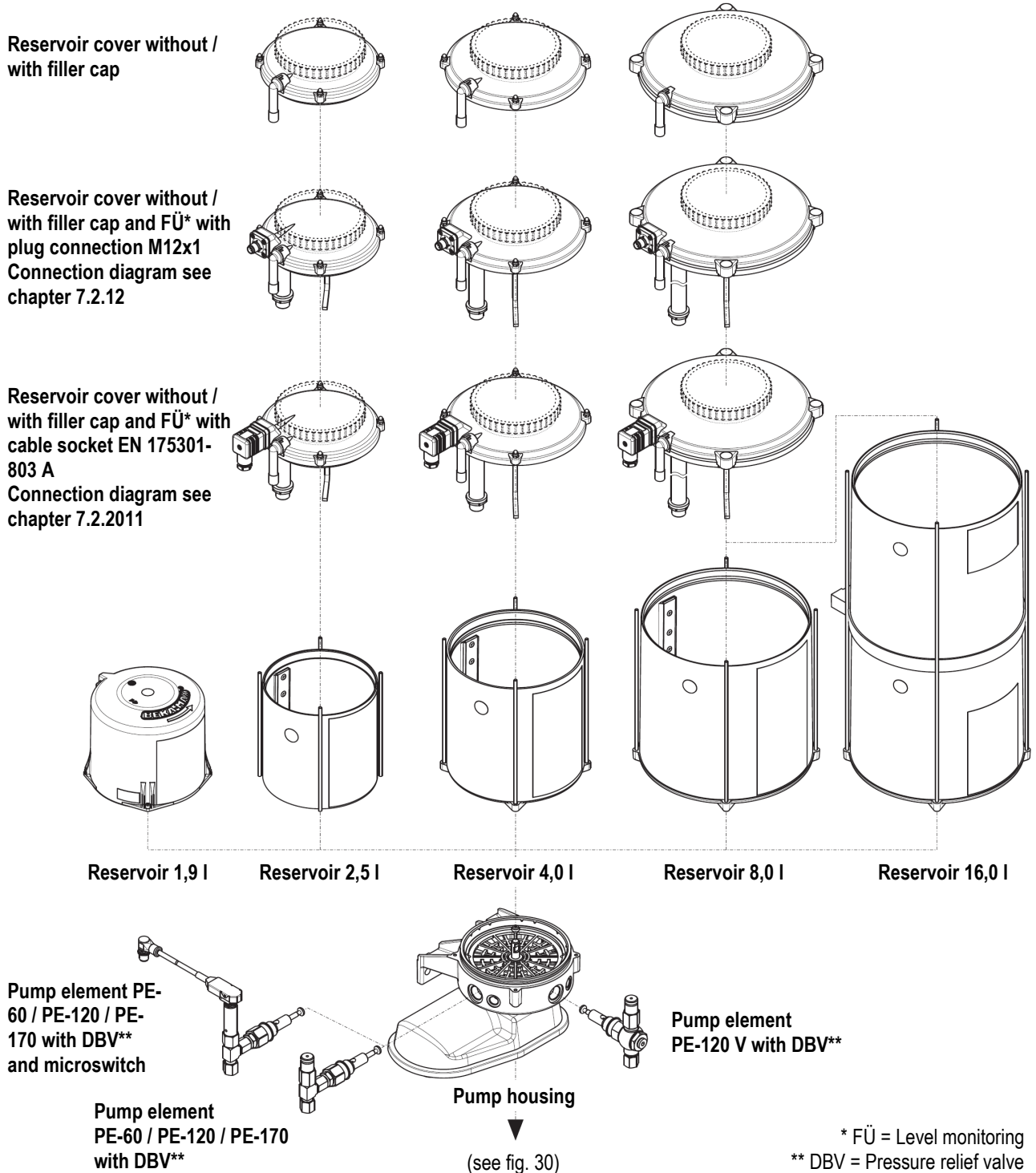

10177337

BAL_EP-1_FKGGM-EP_1221DE_EN_FR_IT_ES

Fig. 30:

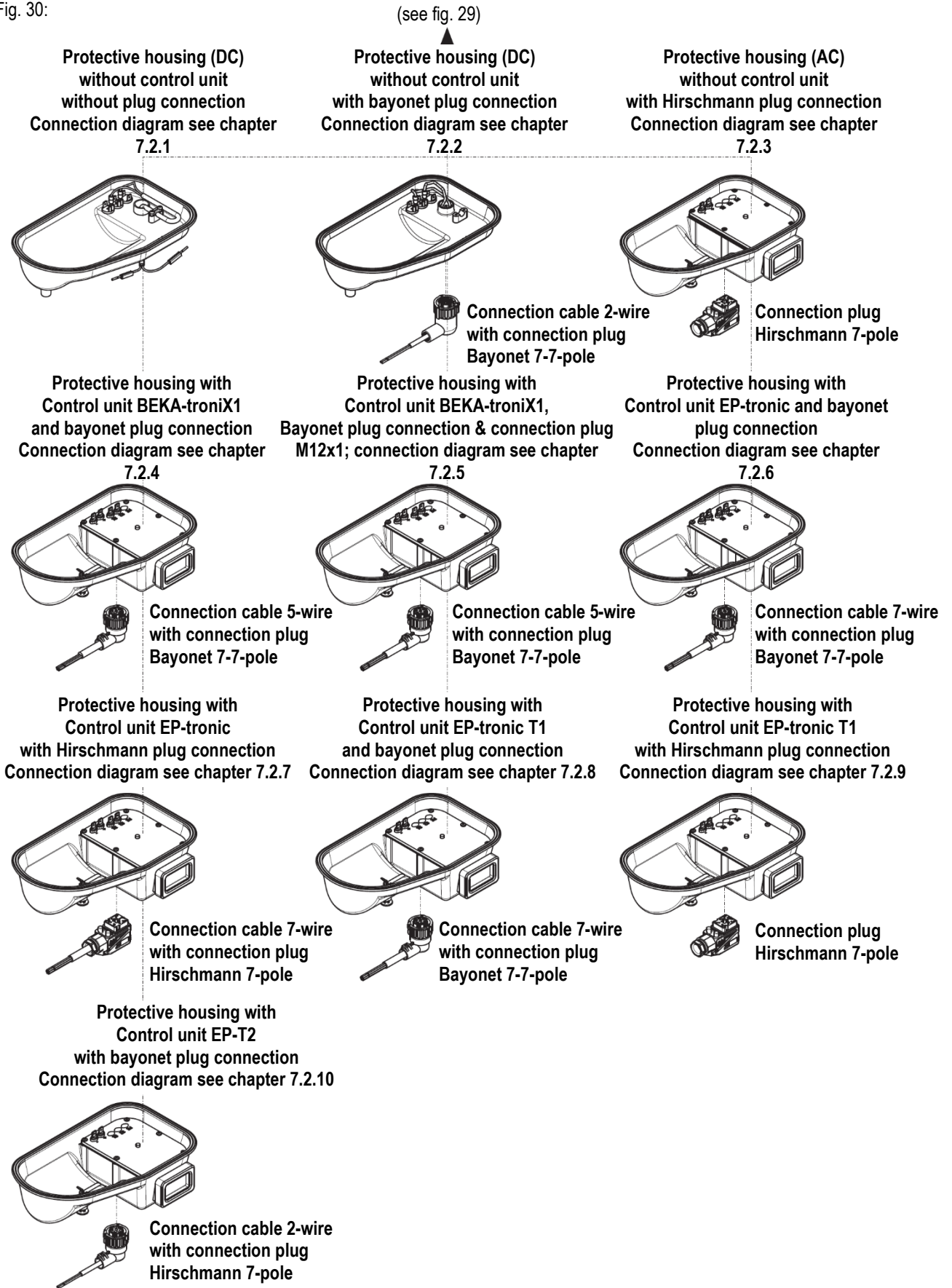

10177337

BAL_EP-1_FKGGM-EP_1221DE_EN_FR_IT_ES

9.3 Functional description of the device

The following positions are shown in fig. 31.

A DC motor (pos. 1) drives a shaft (pos. 2) uniformly via a gearbox. On this shaft there is an eccentric (pos. 3), in the groove of which the conveying pistons (pos. 4) of the pump elements (pos. 5) are suspended. The rotary movement of the eccentric presses the conveying pistons and thus also the lubricant (pos. 6) into the pump element body (= delivery stroke). The further rotary movement of the eccentric causes the conveying pistons to be pulled out of the pump element body again, thereby sucking in new lubricant from the reservoir (pos. 7) (= suction stroke).

Check valves (pos. 8) are installed in the pump elements to prevent lubricant which has already been displaced from being sucked back. Up to three pump elements can be installed in the device. Outlets that are not used must be closed with a screw plug (pos. 9) (part no.: 10101462). Further information on the pump elements can be found in chapter 9.4 "Pump elements".

In order to ensure problem-free suction of the lubricant, the device is equipped with an agitator blade (pos. 10). The agitator blade expels any air pockets in the lubricant and simultaneously forces the lubricant into the suction chamber.

The level in the reservoir of the device can be monitored by a level monitor (pos. 11). The level monitor emits a signal when the level in the reservoir falls below the set value or rises above the set value. Further information can be found in chapter 10 "Level monitoring". A pressure relief valve (pos. 12; optional) fitted to the pump element protects the device and the lubrication system from damage caused by excessive pressure. It is set to 290 bar (standard).

The device is suitable for different applications and is therefore available in different versions, e.g.:

- without integrated control unit (for external control SPS or on-board computer or for external control unit TroniX1-e or Tronic-e)
- with integrated control unit BEKA-troniX1 or EP-tronic (for systems with continuous power supply)
- with integrated control unit EP-tronic T1 or EP-T2 (for systems without continuous power supply)

The function of the different integrated control units can be found in chapter 11 "Integrated control unit".

Fig. 31:

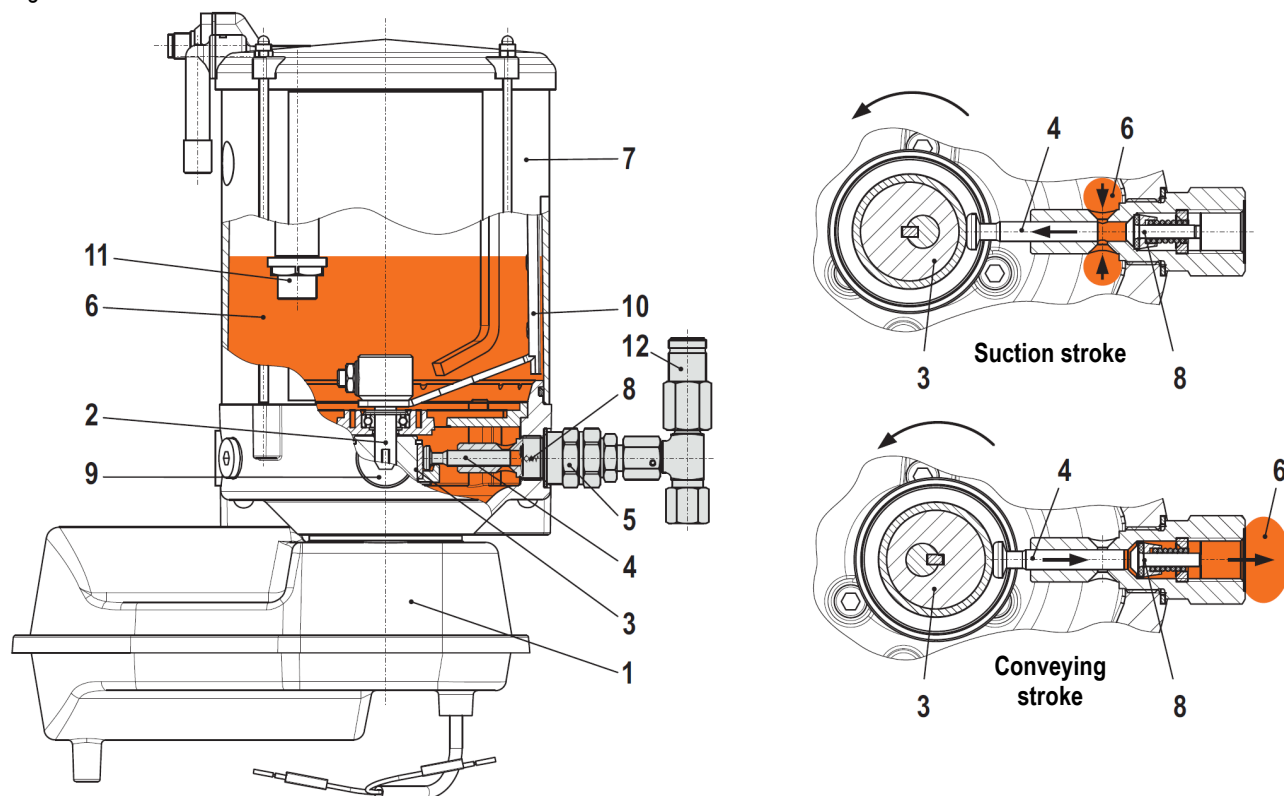

10177337

BAL_EP-1_FKGGM-EP_1221DE_EN_FR_IT_ES

9.4 Pump elements

Different types of pump elements can be installed in the device. Each pump element type is available with different pipe connections and with or without pressure relief valve.

9.4.1 Pump elements PE-120 V

The flow rate of the pump element PE-120 V can be adjusted in the range of 0.04 cm³/stroke and 0.12 cm³/stroke. On delivery the pump element is set to full stroke.

Fig. 32:

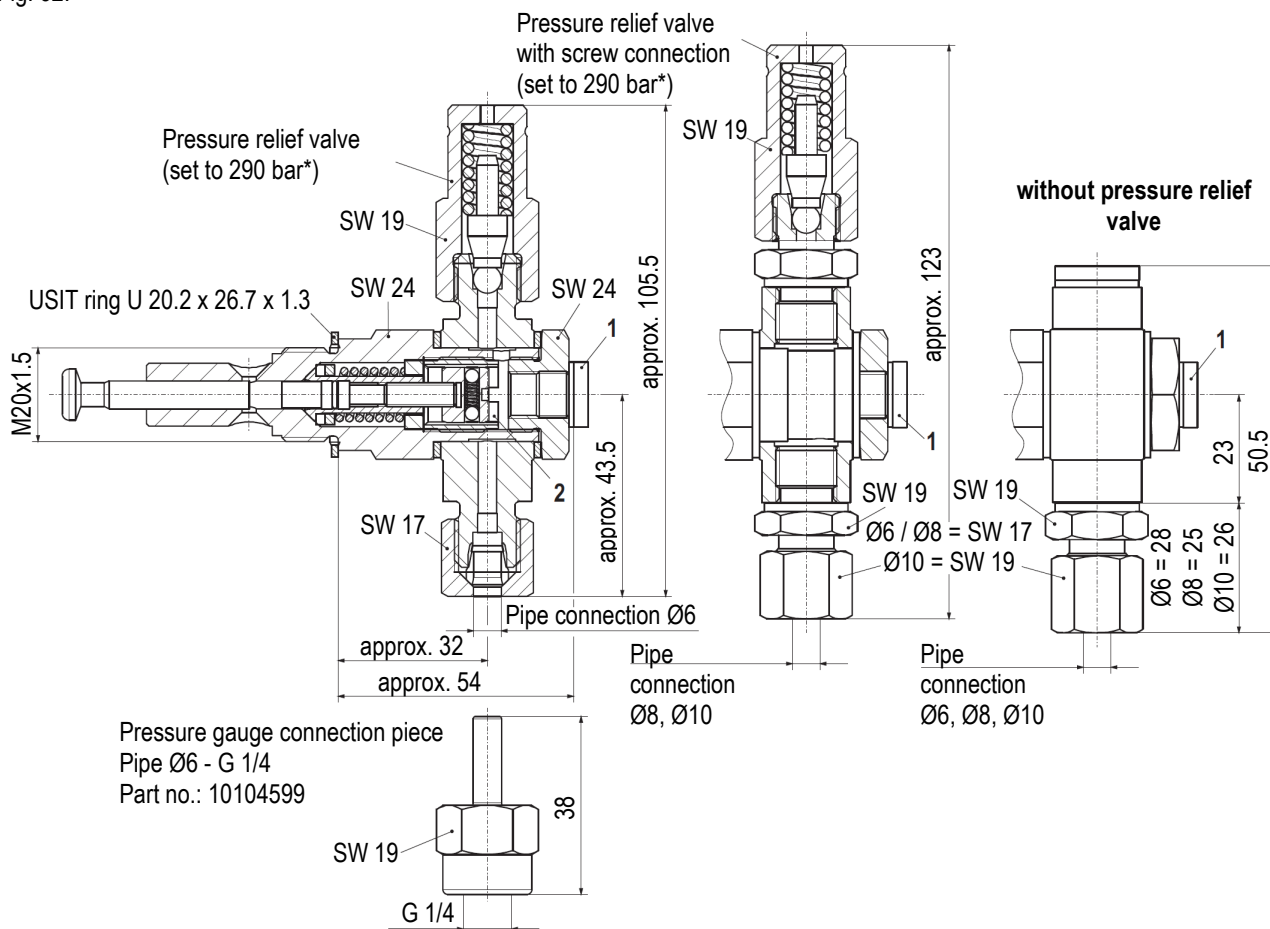

* Standard

Adjustment of the flow rate

- Remove the screw plug (pos. 1, see fig. 32) with an hexagon socket key SW5.
- Adjust the set screw (pos. 2, see fig. 32) with a screwdriver until the required flow rate is reached.
- Turning clockwise reduces the flow rate.
- Turning counterclockwise increases the flow rate.
- 1 turn of the set screw corresponds to 2 detents. The set screw can be adjusted by a maximum of 6 detents (3 turns, see fig. 33).

Fig. 33:

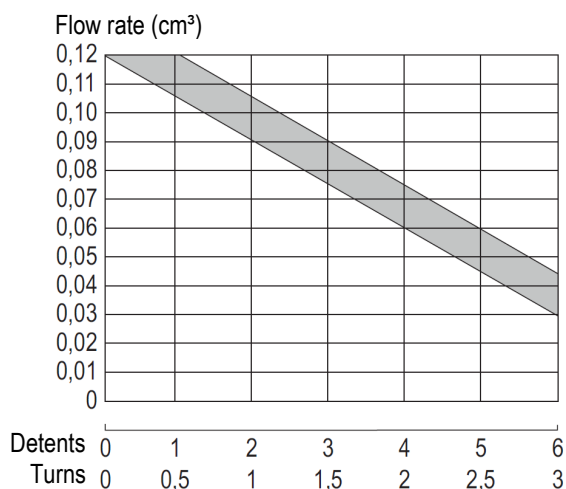

10177337

BAL_EP-1_FKGGM-EP_1221DE_EN_FR_IT_ES

9.4.2 Pump elements PE-60, PE-120 and PE-170

The pump elements PE-60, PE-120 and PE-170 are intended for use in progressive lubrication systems. The flow rate of these pump elements is set to 0.06 cm³/stroke (PE-60), 0.12 cm³/stroke (PE-120) or 0.17 cm³/stroke (PE-170) and cannot be adjusted.

Fig. 34:

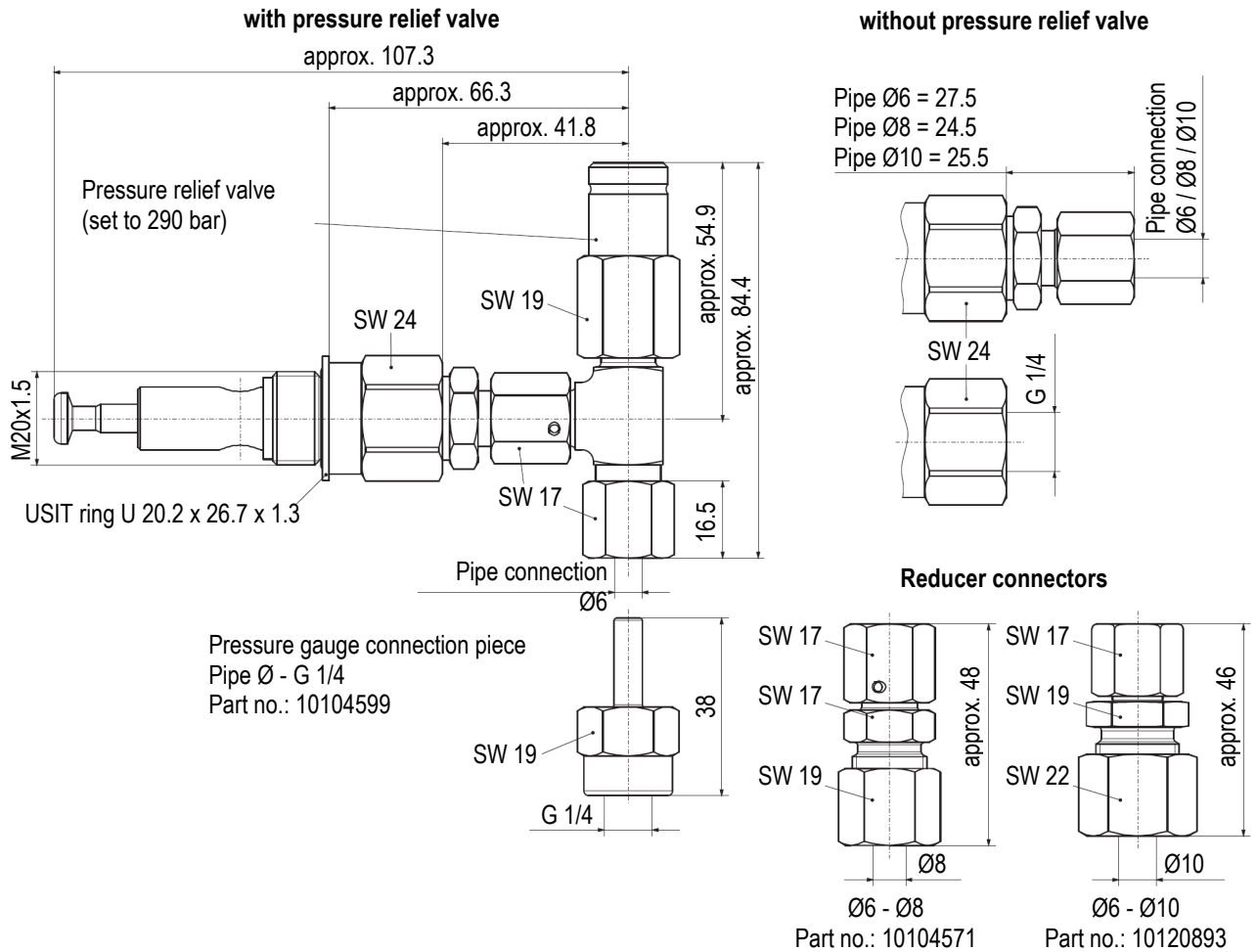

Each pump element type has its own marking to enable visual differentiation (see fig. 35).

Fig. 35:

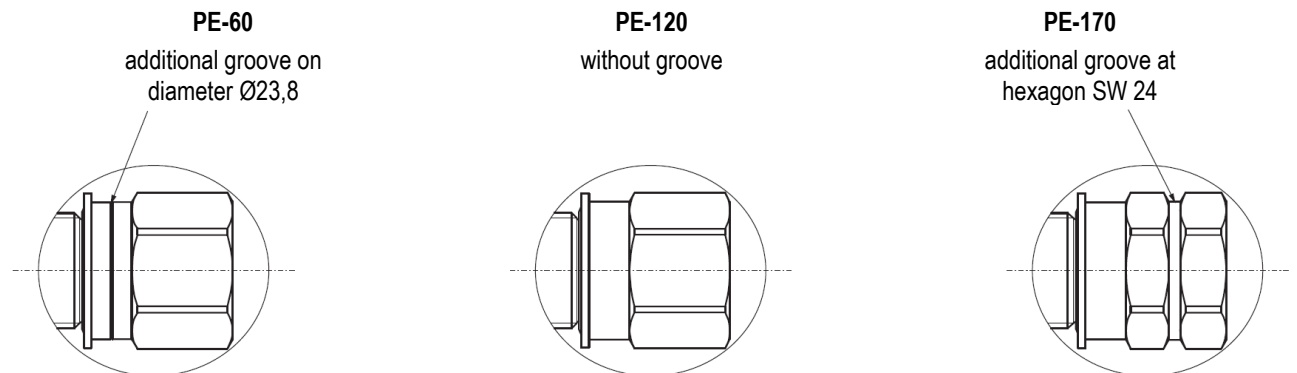

10177337

BAL_EP-1_FKGGM-EP_1221DE_EN_FR_IT_ES

9.4.3 Order numbers of the pump elements

Pump element	Pipe connection	Part no. (PE* without DBV**)	Part no. (PE* with DBV**)
PE-60	Ø6 mm	10166382	10164215
	Ø8 mm	upon request	upon request
	Ø10 mm	upon request	upon request
	G1/4	10138177	---
PE-120	Ø6 mm	10158800	10128653
	Ø8 mm	10166095	10162991
	Ø10 mm	10170270	10166182
	G1/4	10110114	---
PE-170	Ø6 mm	10161764	10127322
	Ø8 mm	10161766	10150864
	Ø10 mm	10166594	10166852
	G1/4	10110205	---
PE-120 V	Ø6 mm	10131623	10127264
	Ø8 mm	10151371	10135000
	Ø10 mm	10164806	10164851
	G1/4	10144206	10135640

* PE = Pump element

** DBV = Pressure relief valve

Note!

If these pump elements are ordered separately, the seal is already included in the scope of delivery and does not have to be ordered separately.

9.5 Pressure relief valves

The lubrication circuits connected to the device can each be protected by a pressure relief valve which can be fitted to a pump element.

9.5.1 Pressure relief valves without microswitch

If the pressure in the lubrication system rises above the value set on the pressure relief valve, the pressure relief valve opens and the lubricant escapes at the top of the valve (see fig. 36).

Fig. 36:

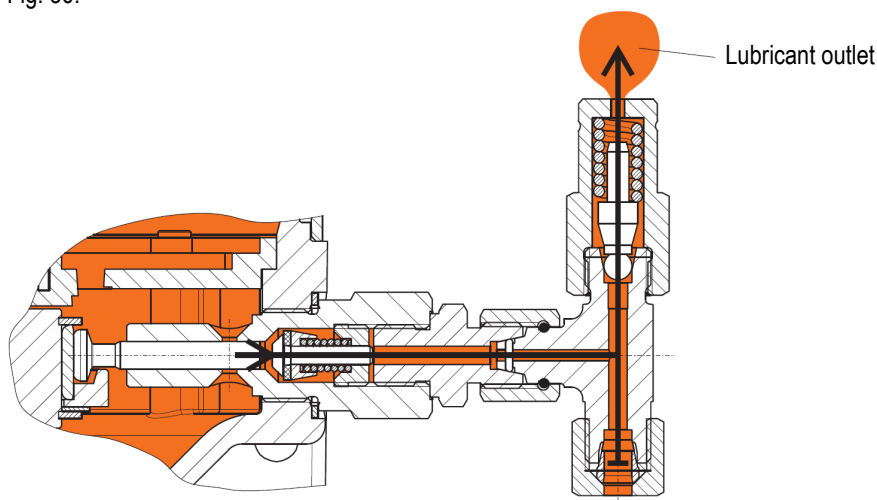

Lubricant can escape at the pressure relief valve under high pressure (290 bar)!

Wear appropriate personal protective equipment (including safety glasses) and do not stay directly in the area of the pressure relief valve if there is a malfunction on the device.

Only work on the device when it is in a de-energised and depressurised state!

Fig. 37:

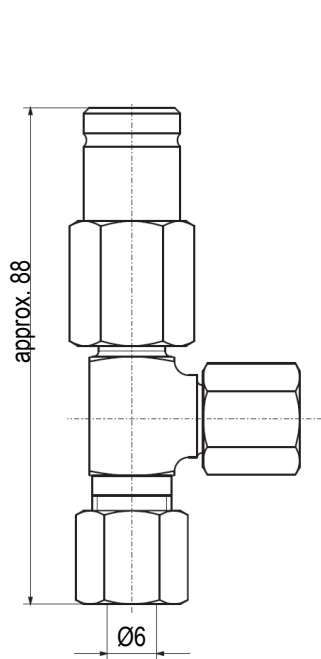

Pressure relief valve
for PE-60, PE-120 and PE-170
set to 290 bar
Part no.: 10101726

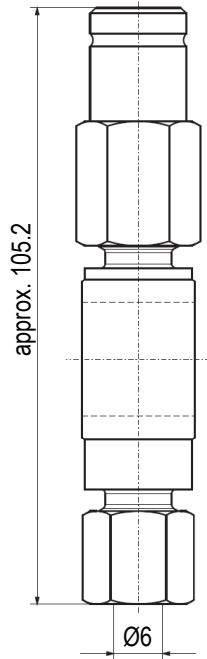

Pressure relief valve for PE-120 V
set to 290 bar
Part no.: 10135641

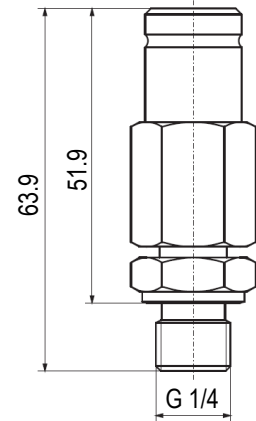

Pressure relief valve
with screw connection, for PE-120
V
set to 290 bar
Part no.: 10106803

9.5.2 Pressure relief valves with microswitch

The maximum operating pressure in the lubrication system can be monitored electronically by means of a microswitch fitted to the pressure relief valve.

The microswitch is actuated when the pressure in the lubrication system rises above the value set on the pressure relief valve (see fig. 38). The signal emitted by the microswitch can be used for customer-specific purposes, e.g. to switch off the device. In addition, the control units BEKA-troniX1 and EP-tronic can evaluate the signal of the microswitch (see chapter 11 "Integrated control unit").

Fig. 38:

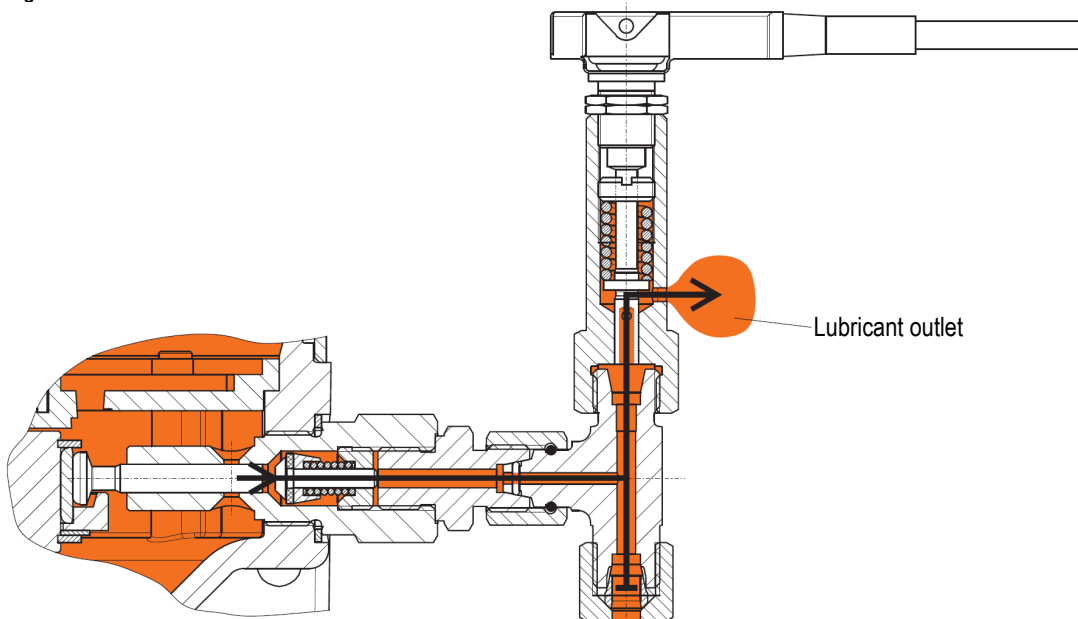

10177337

BAL_EP-1_FKGM-EP_1221DE_EN_FR_IT_ES

Technical data of the microswitch

Supply voltage:	10 to 60 V DC
Current load max:	I = 1.7 A
Contact type:	Changeover contact
Temperature range:	-25°C to +85°C
Protection class:	IP 67
Connection:	Cable 0.5 m long, welded (standard)

Connection diagram*

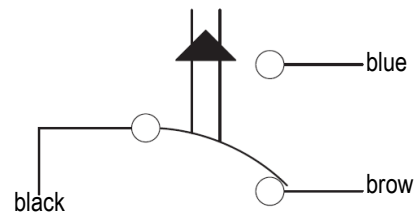

* Connection diagram for connection to a control unit, see chapter 7.2.5 (BEKA-troniX1); chapter 7.2.6 and 7.2.7 (EP-tronic)



Lubricant can escape at the pressure relief valve under high pressure (290 bar)!
Wear appropriate personal protective equipment (including safety glasses) and do not stay directly in the area of the pressure relief valve if there is a malfunction on the device.

Only work on the device when it is in a de-energised and depressurised state!

Fig. 39:

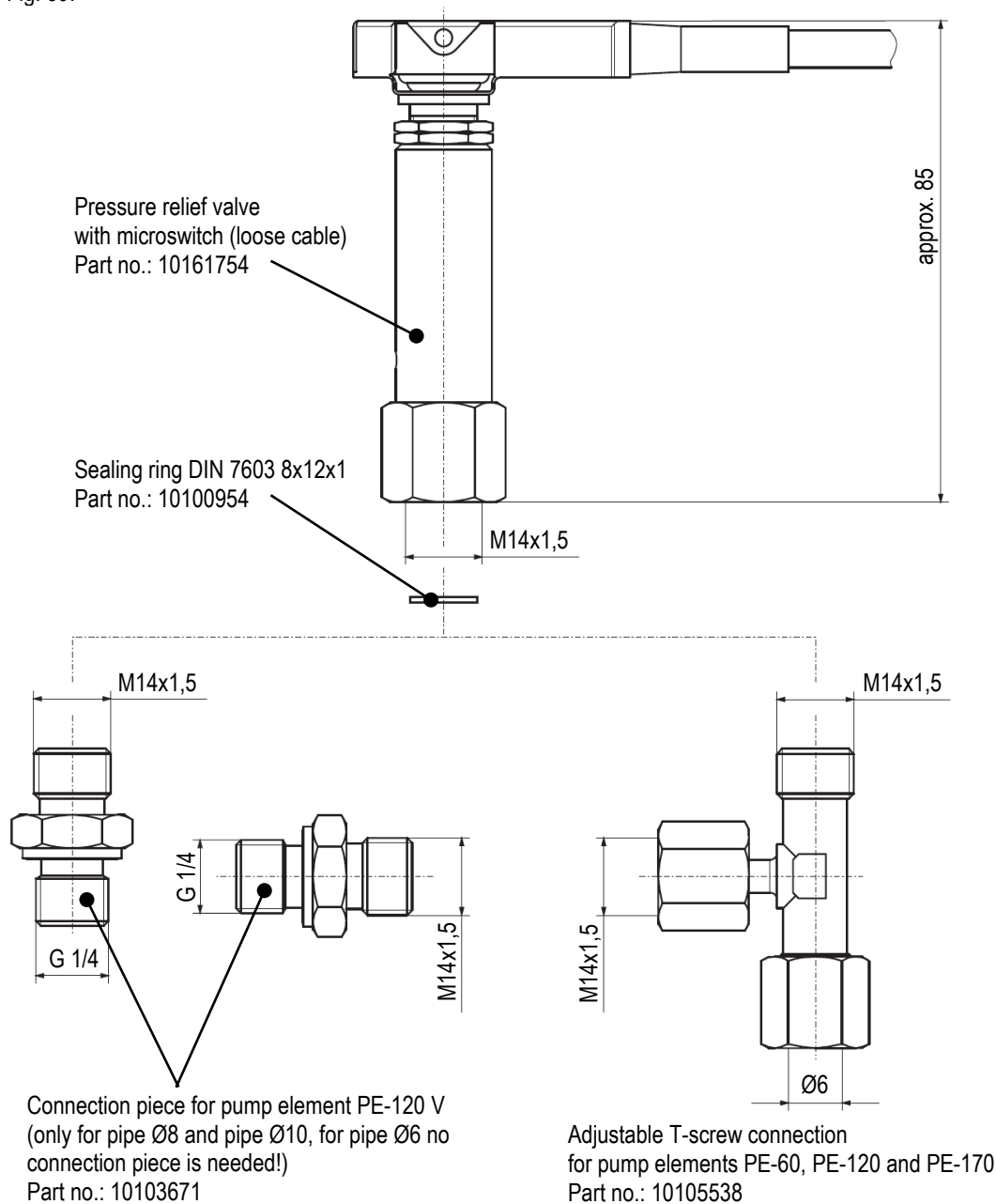

10177337

BAL_EP-1_FKGGM-EP_1221DE_EN_FR_IT_ES

10. Level monitoring

The current level in the reservoir can be visually checked at any time on the level sticker (see fig. 40).

Fig. 40:

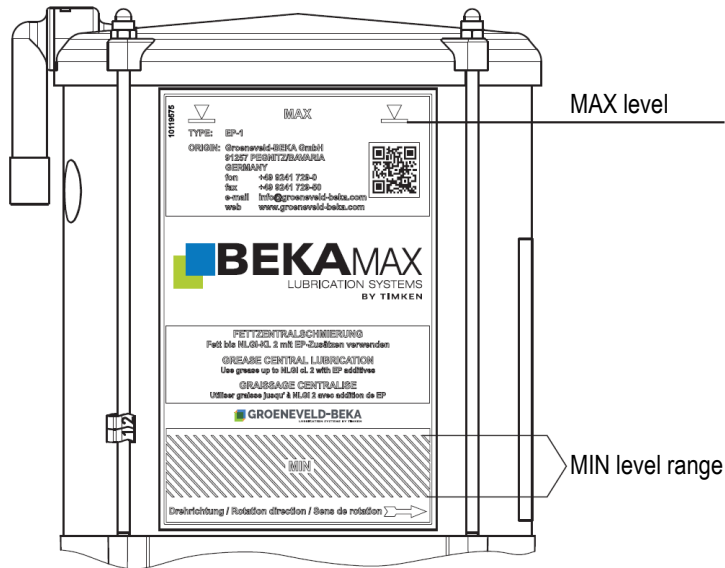

The device can also be supplied with electrical level monitoring as an option.

The level in the reservoir of the device is monitored by one or two proximity switches. This reliably prevents accidental emptying and / or overfilling of the device. The level monitor is located in the reservoir cover of the device as standard and can be supplied with two different electrical connections:

- Plug connection M12x1 (see fig. 41)

Fig. 41:

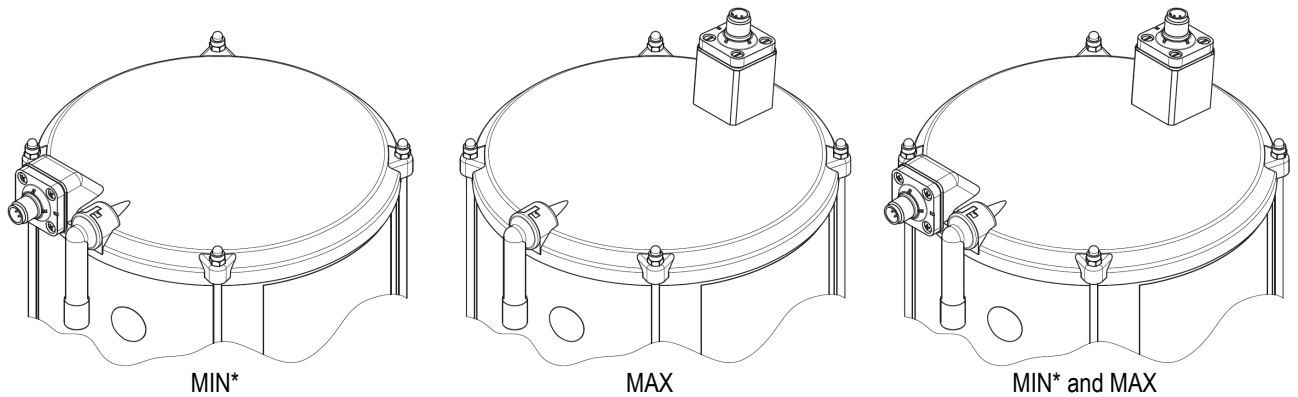

* Connection diagram see chapter 7.2.12

10177337

BAL_EP-1_FKGM-EP_1221DE_EN_FR_IT_ES

- Cable socket according to EN 175301-803A (see fig. 42)

Fig. 42:

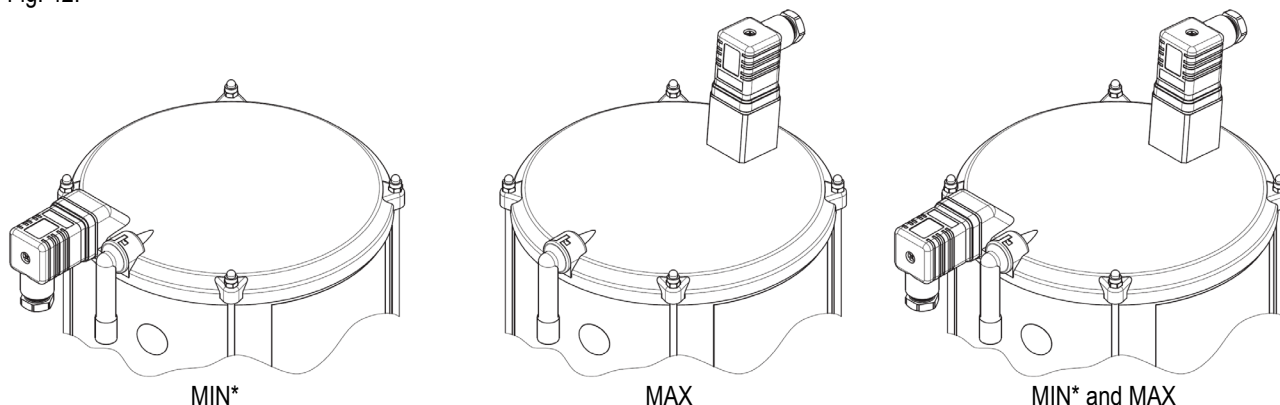

* Connection diagram see chapter 7.1.11

Depending on the version and area of application of the device, the level monitoring can be configured accordingly. For more information, refer to chapter 10.4 "Level monitoring code".

Note!

On devices with a **1.9 litre reservoir**, the level can **only be monitored optically**. Electrical level monitoring is **not possible**.

The level monitoring can be connected to an external control (e.g. on-board computer or PLC).

In the version **MIN level, plug connection M12x1 and voltage range 10 - 60 V DC**, the level monitoring can also be evaluated by the integrated control units BEKA-troniX1 and EP-tronic.

10.1 Technical data

General:

Protection class: IP 67
 Short-circuit resistance of the output: yes
 Connection: Compact plug connection 3-pole + PE
 4-pole, M12x1 pluggable

Standard version 10 - 60 V DC:

Voltage range: 10 to 60 V DC
 Switching current: max. 200 mA
 Current consumption (without load): < 20 mA
 Temperature range: -20°C to +70°C
 Switching type: positive switching (PNP) NO contact
 positive switching (PNP) NC contact

Version 90 - 250 V DC:

Note!

Only for version with cable socket according to EN 175301-803A.

Voltage range: 90 to 250 V DC
 Switching current: max. 250 mA
 Minimum load current: 5 mA
 Temperature range: -20°C to +70°C
 Switching type: NO contact

10177337

BAL_EP-1_FKGGM-EP_1221DE_EN_FR_IT_ES

Low temperature design:
Note!
Only for version with plug connection M12x1.

 Voltage range: 12 to 30 V DC
 Switching current:max. 20 mA
 Current consumption (without load): < 35 mA
 Temperature range:-40°C to +70°C
 Switching type: positive switching NO contact
 positive switching NC contact

10.2 MIN level

The level monitoring contact can be used either as a NO contact or as a NC contact. Depending on the type of connection, the function of the level monitoring changes (see fig. 43). To ensure wire break monitoring, the NO contact is preferred.

Fig. 43:

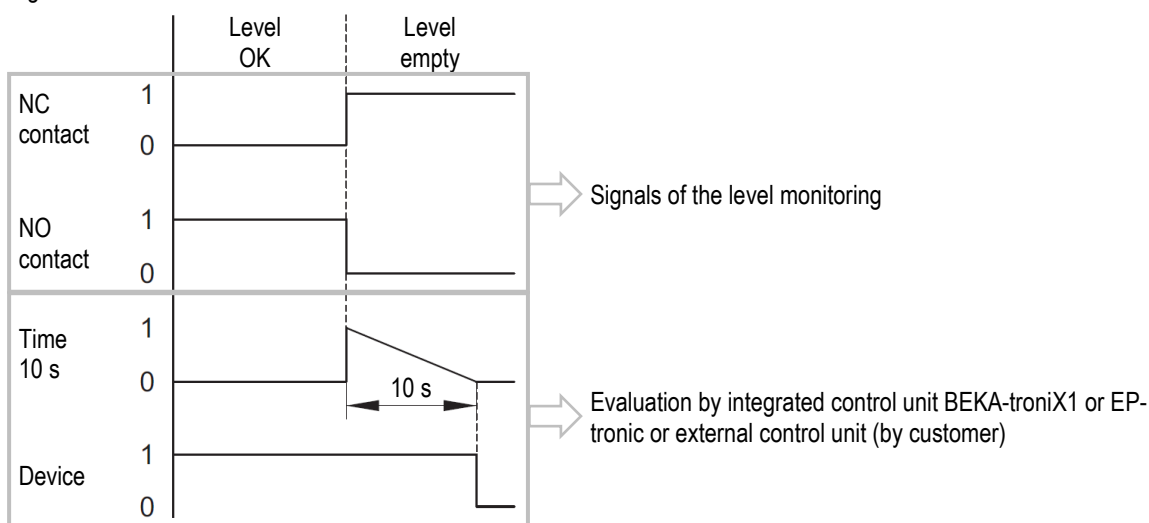
10.2.1 Functionality NO contact

When the black wire is connected, the level monitoring contact is used as a NO contact (see chapter 7.2.11 "Connection diagram for level monitoring with cable socket EN 175301-803 A" and chapter 7.2.12 "Connection diagram for level monitoring with plug connection M12x1"). The unused wire must be insulated accordingly.

The level monitor emits a signal as long as there is sufficient lubricant in the reservoir. The signal is interrupted when the level falls below the MIN value.

Evaluation by external control

Switch off the device if the signal is absent for more than 10 seconds so that no air is pumped into the lubrication system.

Evaluation by integrated control unit

The integrated control unit switches off the device if the signal is absent for more than 10 seconds. The device starts to work automatically as soon as lubricant has been refilled.

10177337

BAL_EP-1_FKGGM-EP_1221DE_EN_FR_IT_ES

10.2.2 Functionality NC contact

When the white wire is connected, the level monitoring contact is used as a NC contact (see chapter 7.2.11 "Connection diagram for level monitoring with cable socket EN 175301-803 A" and chapter 7.2.12 "Connection diagram for level monitoring with plug connection M12x1"). The unused wire must be insulated accordingly.

The level monitor emits a signal when the level falls below the MIN value.

Evaluation by external control

Switch off the device if the signal remains constantly on for more than 10 seconds so that no air is pumped into the lubrication system.

Evaluation by integrated control unit

The integrated control unit switches off the device if the signal remains constantly off for more than 10 seconds. The device starts to work automatically as soon as lubricant has been refilled.

10.3 MAX level

The level monitoring contact can be used either as a NO contact or as a NC contact. Depending on the type of connection, the function of the level monitoring changes (see fig. 44). To ensure overflow protection, the NC contact must be used.

Fig. 44:

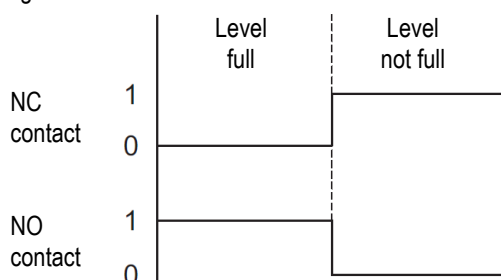

10.3.1 Functionality NO contact

When the black wire is connected, the level monitoring contact becomes a normally open contact (see chapter 7.2.11 "Connection diagram for level monitoring with cable socket EN 175301-803 A" and chapter 7.2.12 "Connection diagram for level monitoring with plug connection M12x1"). The unused wire must be insulated accordingly.

The level monitor emits a signal when the level rises above the MAX value. The emitted signal must be evaluated by the customer.

10.3.2 Functionality NC contact

When the white wire is connected, the level monitoring contact is used as a NC contact (see chapter 7.2.11 "Connection diagram for level monitoring with cable socket EN 175301-803 A" and chapter 7.2.12 "Connection diagram for level monitoring with plug connection M12x1"). The unused wire must be insulated accordingly.

The level monitor emits a signal as long as the lubricant in the reservoir is below the MAX value. The signal is interrupted when the level rises above the MAX value. The emitted signal must be evaluated by the customer.

10177337

BAL_EP-1_FKGGM-EP_1221DE_EN_FR_IT_ES

10.4 Code of the level monitoring

10.4.1 Level monitoring with plug connection M12x1

Type no.	4458			4458 X X X X 00			
Code	4458						
Execution	Standard up to -20°C		Low temperature down to -40°C				
	MIN	MIN and MAX	MIN	MIN and MAX			
Operating voltage	10 - 60 V DC	10 - 60 V DC	12 - 30 V DC	12 - 30 V DC			
Code	1	2	5	6			
Reservoir capacity (l)	2.5	4	8 (1-piece)				
	1	2	3				
Connection type	M12x1	M12x1 with plug		M12x1 with angular socket			
Connection cable	without	angular, 0,6 m long, 4-pole (connection to integrated control unit)		free cable end 5 m long, 4-pole (connection to external control)			
Code	1	2*		3			
Filling cap (only possible with FÜ MIN)	without	with					
	Code		1	2			
Special version	without						
Code	00						

* only possible with FÜ MIN, 10 - 60 V DC

10.4.2 Level monitoring with cable socket EN 175301-803 A

Type no.	4458			4458 X X X X 00			
Code	4458						
Execution	MIN	MIN and MAX	MIN	MIN and MAX			
	Operating voltage	10 - 60 V DC	10 - 60 V DC	90 - 250 V AC	90 - 250 V AC		
Code	1	2	3	4			
Reservoir capacity (l)	2.5	4	8 (1-piece)				
	1	2	3				
Connection type	Cable socket according to EN 175301-803 A						
Switching type	NO contact	NO contact		NC contact (only for 10 - 60 V DC)	NC contact (only for 10 - 60 V DC)		
Scope of delivery	plug only	Plug with cable socket		plug only	Plug with cable socket		
Code	4	5		6	7		
Filling cap (only possible with FÜ MIN)	without	with					
	Code		1	2			
Special version	without						
Code	00						

10177337

BAL_EP-1_FKGGM-EP_1221DE_EN_FR_IT_ES

11. Integrated control unit

Progressive lubrication systems can be controlled with a control unit integrated in the device. The following control units can optionally be integrated into the device:

- BEKA-troniX1 (see chapter 11.1 "BEKA-troniX1")
- EP-tronic (see chapter 11.2 "EP-tronic")
- EP-tronic T1 (see chapter 11.3 "EP-tronic T1")
- EP-T2 (see chapter 11.4 "EP-T2")

The integrated control units can be ordered directly with the device or retrofitted (see chapter 16 "Code" and chapter 12.3 "Changing the integrated control unit").

The integrated control units operate according to the lubrication cycle.

A lubrication cycle consists of the cycle duration and the lubrication time (pump running time), which is included in the cycle duration. Cycle duration is the period from the start of one lubrication to the start of the next lubrication (see fig. 45).

Fig. 45:

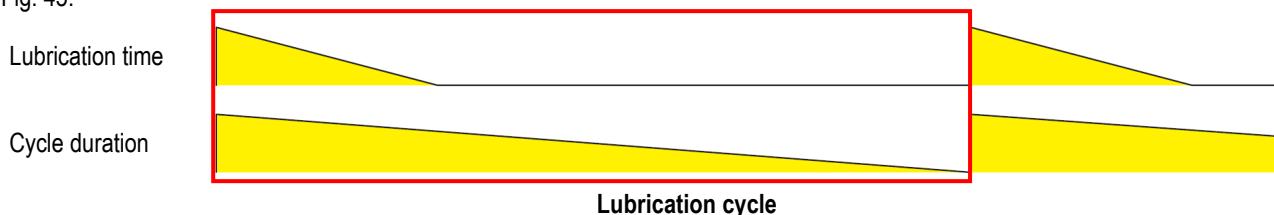

11.1 BEKA-troniX1

With the integrated control unit BEKA-troniX1 the **cycle duration** is determined **time-dependently**.

The **lubrication time** can be determined **time-dependently** or **rotation-dependently**.

Functions:

The following functions can be evaluated with the integrated control unit:

- Level monitoring
- System pressure monitoring

Note!

These functions can only be evaluated if the BEKA-troniX1 control unit is designed with the additional M12x1 plug connections (see also chapter 7.2.5 "Connection diagram for devices with BEKA-troniX1 with bayonet plug connection and M12x1 plug connections").

Signal indicators:

The following messages are indicated by the integrated control unit by the red and green LED in the viewing window of the protective housing (see chapter 15.3.1 "Signal indicators BEKA-troniX1"):

- Functional readiness
- Lubrication running
- The set number of pump revolutions was not reached within the revolution monitoring time
- Reservoir empty
- System pressure too high
- CPU / memory defective
- Test lubrication running

Operational database:

The integrated control unit has an operating database in which the following values are stored:

- Data of the control unit (type, version, serial number, production date)
- Current settings (cycle duration, operating mode of the lubrication time, lubrication time, monitoring times)
- Statistical values (operating hours, running time of the device, number of intermediate lubrications, number of level errors, number of rotation errors, number of total diagnoses, etc.)
- Date and time of the last diagnosis

Note!

The operating mode of the lubrication time, the setting ranges of the cycle duration and lubrication time and the setting of the monitoring time can be changed at any time with the diagnostic software **BEKA-DiSys** (with the version currently stored under www.groeneveld-beka.com).

11.1.1 Function description

Fig. 46:

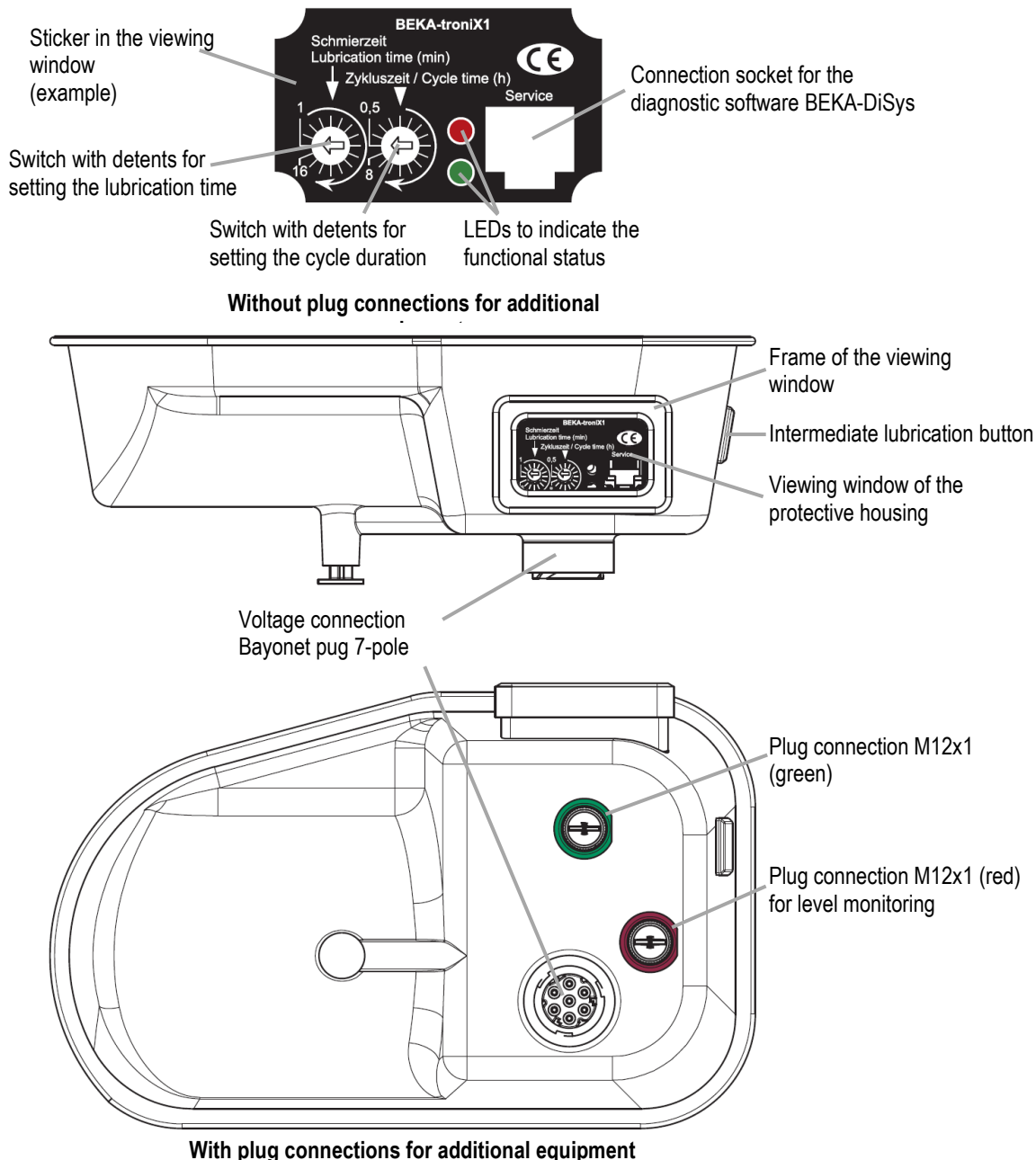

Lubrication starts when the integrated control unit is connected for the first time. Each time the voltage is switched on (ignition), the red and green LEDs in the viewing window of the protective housing light up for approx. 1.5 seconds, indicating that the integrated control unit is ready for operation. If the voltage is interrupted during the cycle or during the lubrication time (ignition switched off), the data is stored in the operating database of the integrated control unit. If the voltage (ignition) is switched on again, the cycle sequence starts where it was interrupted before. When the voltage is switched on, intermediate lubrication can be triggered at any time by pressing the intermediate lubrication button. The current cycle data is deleted and a new lubrication cycle starts immediately. Some faults must be reset after troubleshooting by pressing the intermediate lubrication button (see chapter 15 "Troubleshooting"). The device then immediately starts a lubrication cycle.

10177337

BAL_EP-1_FKGM-EP_1221DE_EN_FR_IT_ES

11.1.2 Changing and setting the parameters

The setting ranges of the lubrication time and the cycle duration and the operating mode of the lubrication time can be changed at any time with the diagnostic software **BEKA-DiSys** (with the version currently stored under www.groeneveld-beka.com).

If the parameters are changed, the sticker in the viewing window of the protective housing must be changed accordingly.

The stickers for the viewing window can be ordered as required:

		Time-dependent cycle duration		
		0,5 - 8 h	2 - 32 min	2 - 32 h
Time-dependent lubrication time				
I	1 - 16 min	10121037	10121042	10121045
II	2 - 32 min	10121048	10121053	10121076
III	2 - 32 s	10121092	10121101	10121111
Rotation-dependent lubrication time				
I	1 - 16 rotations	10121115	10121146	10121149
II	10 - 160 rotations	10121151	10121153	10121156
III	170 - 320 rotations	10121171	10121173	10121174

Within a setting range, the lubrication time and the cycle duration can be changed with a flat screwdriver at the switches with detents in the viewing window of the protective housing (see fig. 46).

To do this, remove the frame on the viewing window of the protective housing using a flat screwdriver, unscrew the four recessed-head screws and remove the transparent viewing window.

Attention!

After setting the parameters, the viewing window and frame must be **closed** again **properly**, otherwise **water** may **enter** the integrated control unit and **destroy** it!

11.1.3 Operating mode time-dependent cycle duration

In the time-dependent cycle duration operating mode, the cycle duration can be set in hours or minutes, depending on the selected setting range. The setting range can be changed with the diagnostic software **BEKA-DiSys** (with the current version stored under www.groeneveld-beka.com).

Fig. 47:



Setting ranges of the time-dependent cycle duration:

- 0.5 to 8 h (16 detents of 0.5 h each)
- 2 to 32 min (16 detents of 2 min each)
- 2 to 32 h (16 detents of 2 h each)

The cycle duration (within a setting range) can be set with the right-hand switch with detents in the viewing window of the protective housing (see fig. 46).

11.1.4 Operating mode time-dependent lubrication time

In the time-dependent lubrication time operating mode, the lubrication time can be set in minutes or seconds, depending on the selected setting range. The setting range can be changed with the diagnostic software **BEKA-DiSys** (with the current version stored under www.groeneveld-beka.com).

Fig. 48:



Setting ranges of the time-dependent lubrication time:

- 1 to 16 min (16 detents of 1 min each)
- 2 to 32 min (16 detents of 2 min each)
- 2 to 32 s (16 detents of 2 s each)

The lubrication time (within a setting range) can be set using the left-hand switch with detents in the viewing window of the protective housing (see fig. 46).

11.1.5 Operating mode rotation-dependent lubrication time

In the rotation-dependent lubrication time operating mode, the lubrication time is determined by the number of pump rotations counted. For this purpose, a sensor is built into the device, which sends a signal to the control unit with each pump rotation. If the control unit does not receive a signal within the adjustable revolution monitoring time (standard setting 30 s), it displays an error (see chapter 15.3.1 "Signal indicators BEKA-troniX1").

After the cause of the fault has been eliminated, the fault must be reset by pressing the intermediate lubrication button (see fig. 46).

The setting range and the revolution monitoring time can be changed with the diagnostic software **BEKA-DiSys** (with the version currently stored under www.groeneveld-beka.com).

Fig. 49:

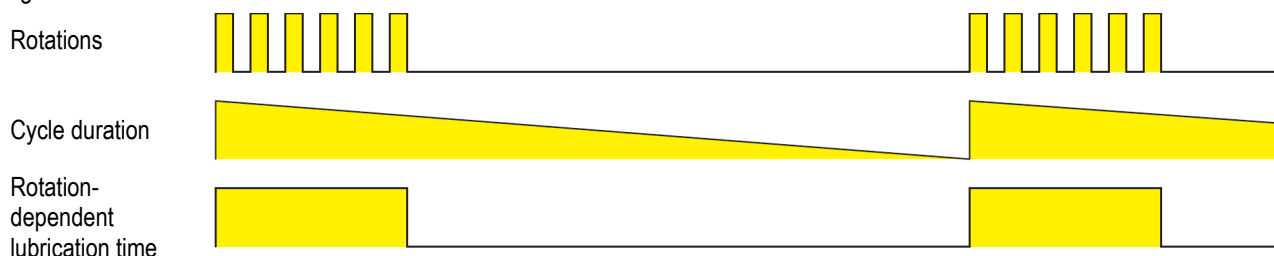

Setting ranges of the rotation-dependent lubrication time:

- 1 to 16 rotations (16 detents of 1 rotation each)
- 10 to 160 rotations (16 detents of 10 rotations each)
- 170 to 320 rotations (16 detents of 10 rotations each)

The lubrication time (within a setting range) can be set using the left-hand switch with detents in the viewing window of the protective housing (see fig. 46).

11.1.6 Level monitoring function

In order to be able to use the *level monitoring* function, the integrated control unit must be designed with the plug connections for the additional equipment (see chapter 16 "Code").

The integrated control unit can evaluate the signal of the level monitoring in the version **MIN level, plug connection M12x1 and voltage range 10 - 60 V DC**. The level monitoring can be connected to the M12x1 plug connection marked in red (for level monitoring, see fig. 46; for connection diagram, see chapter 7.2.5 "Connection diagram for devices with BEKA-troniX1 with bayonet plug connection and plug connections M12x1").

Further information can be found in chapter 10 "Level monitoring".

Note!

If the function *level monitoring* is not used, the function must be deactivated via the diagnostic software **BEKA-DiSys** (with the version currently stored under www.groeneveld-beka.com). In addition, the existing connection must be closed with a protective cap (item no. 10106213).

11.1.7 System pressure monitoring function

The operating pressure in the lubrication system can be monitored by means of a microswitch fitted to the pressure relief valve (see chapter 9.5.2 "Pressure relief valves with microswitch").

If the pressure in the lubrication system rises above the set value, the pressure relief valve opens and the microswitch is actuated. The microswitch sends a signal to the integrated control unit. This switches off the device and indicates an error (see chapter 15.3.1 "Signal indicators BEKA-troniX1").

After eliminating the cause of the error, the error must be reset by pressing the intermediate lubrication button (see fig. 46).

The microswitch can be connected to the M12x1 plug connection marked in green (for system pressure monitoring, see fig. 46; for connection diagram, see chapter 7.2.5 "Connection diagram for devices with BEKA-troniX1 with bayonet plug connection and plug connections M12x1").

The **system pressure monitoring** function is always active, a microswitch can be connected at any time.

11.2 EP-tronic

With the EP-tronic integrated control unit, the **cycle duration** is determined **time-dependently**.
The **lubrication time** can be determined **time-dependently**, **cycle-dependently** or **rotation-dependently**.

Functions:

The following functions can be evaluated with the integrated control unit:

- Level monitoring
- System pressure monitoring

Special functions:

The following special functions can be used with the integrated control unit:

- Adaptation to the operating conditions
- Cycle locked
- External status signal as error signal (signal when an error occurs) or OK signal (signal when everything is OK)

Signal indicators:

The following messages are indicated by the integrated control unit by the red and green LED in the viewing window of the protective housing (see chapter 15.3.2 "Signal indicators EP-tronic"):

- Functional readiness
- Lubrication running
- Set number of cycles of the lubrication time was not reached within the cycle monitoring time of the lubrication time
- The set number of pump revolutions was not reached within the revolution monitoring time
- Reservoir empty
- System pressure too high
- CPU / memory defective
- Test lubrication running

Operational database:

The integrated control unit has an operating database in which the following values are stored:

- Data of the control unit (type, version, serial number, production date)
- RTC (Real-Time-Clock), date and time, also adjustable for other time zones
- Current settings (cycle duration, operating mode of the lubrication time, lubrication time, monitoring times)
- Statistical values (operating hours, running time of the device, number of intermediate lubrications, number of level errors, number of cycle errors, number of rotation errors, number of total diagnoses, etc.)
- Date and time of the last diagnosis
- Error log of the last 100 errors with indication of the error type as well as time and date information
- Event log of the last 100 setting changes with time and date information

Note!

The operating mode of the lubrication time, the setting ranges of the cycle duration and lubrication time and the setting of the monitoring time can be changed at any time with the diagnostic software **BEKA-DiSys** (with the version currently stored under www.groeneveld-beka.com).

11.2.1 Function description

Fig. 50:

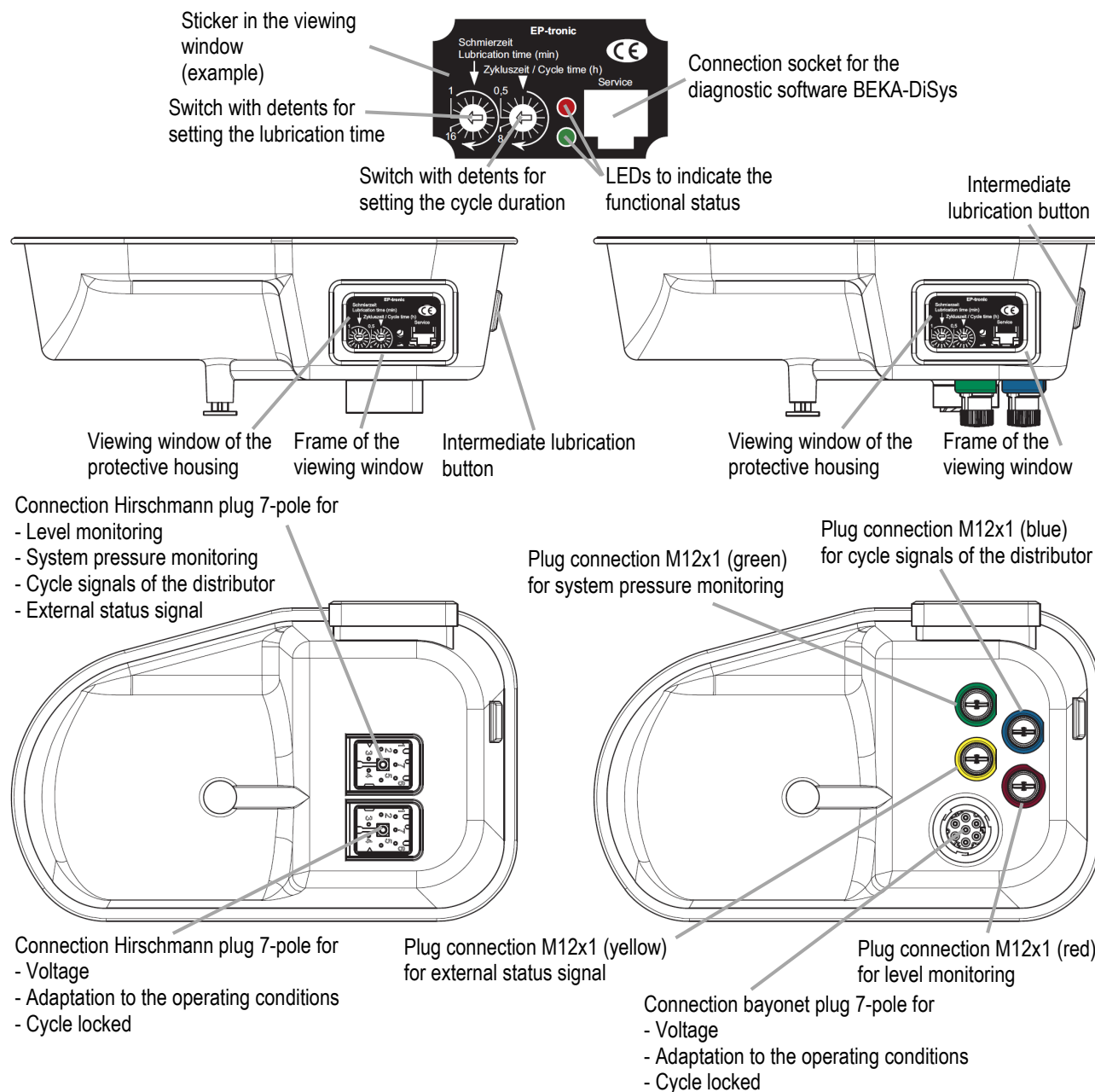

Lubrication starts when the integrated control unit is connected for the first time. Each time the voltage is switched on (ignition), the red and green LEDs in the viewing window of the protective housing light up for approx. 1.5 seconds, indicating that the integrated control unit is ready for operation. If the voltage is interrupted during the cycle or during the lubrication time (ignition switched off), the data is stored in the operating database of the integrated control unit. If the voltage (ignition) is switched on again, the cycle sequence starts where it was interrupted before. When the voltage is switched on, intermediate lubrication can be triggered at any time by pressing the intermediate lubrication button. The current cycle data is deleted and a new lubrication cycle starts immediately. Some faults must be reset after troubleshooting by pressing the intermediate lubrication button (see chapter 15 "Troubleshooting"). The device then immediately starts a lubrication cycle.

10177337

BAL_EP-1_FKGM-EP_1221DE_EN_FR_IT_ES

11.2.2 Changing and setting the parameters

The setting ranges of the lubrication time and the cycle duration and the operating mode of the lubrication time can be changed at any time with the diagnostic software **BEKA-DiSys** (with the version currently stored under www.groeneveld-beka.com).

If the parameters are changed, the sticker in the viewing window of the protective housing must be changed accordingly.

The stickers for the viewing window can be ordered as required:

		Time-dependent cycle duration		
		0,5 - 8 h	2 - 32 min	2 - 32 h
Time-dependent lubrication time				
I	1 - 16 min	10121239	10121243	10121253
II	2 - 32 min	10121257	10121264	10121277
III	2 - 32 s	10121284	10121286	10121291
Cycle-dependent lubrication time				
I	1 - 16 cycles	10120894	10121292	10121304
II	17 - 32 cycles	10121306	10121983	10123180
III	33 - 48 cycles	10123182	10123183	10123187
Rotation-dependent lubrication time				
I	1 - 16 rotations	10123190	10123195	10123196
II	10 - 160 rotations	10123198	10123244	10123246
III	170 - 320 rotations	10123255	10123258	10123259

Within a setting range, the lubrication time and the cycle duration can be changed with a flat screwdriver at the switches with detents in the viewing window of the protective housing (see fig. 49).

To do this, remove the frame on the viewing window of the protective housing using a flat screwdriver, unscrew the four recessed-head screws and remove the transparent viewing window.

Attention!

After setting the parameters, the viewing window and frame must be **closed again properly**, otherwise **water may enter** the integrated control unit and **destroy it!**

11.2.3 Operating mode time-dependent cycle duration

In the time-dependent cycle duration operating mode, the cycle duration can be set in hours or minutes, depending on the selected setting range. The setting range can be changed with the diagnostic software **BEKA-DiSys** (with the version currently stored under www.groeneveld-beka.com).

Fig. 51:



Setting ranges of the time-dependent cycle duration:

- 0.5 to 8 h (16 detents of 0.5 h each)
- 2 to 32 min (16 detents of 2 min each)
- 2 to 32 h (16 detents of 2 h each)

The cycle duration (within a setting range) can be set with the right-hand switch with detents in the viewing window of the protective housing (see fig. 50).

11.2.4 Operating mode time-dependent lubrication time

In the time-dependent lubrication time operating mode, the lubrication time can be set in minutes or seconds, depending on the selected setting range. The setting range can be changed with the diagnostic software **BEKA-DiSys** (with the version currently stored under www.groeneveld-beka.com).

Fig. 52:



Setting ranges of the time-dependent lubrication time:

- 1 to 16 min (16 detents of 1 min each)
- 2 to 32 min (16 detents of 2 min each)
- 2 to 32 s (16 detents of 2 s each)

The lubrication time (within a setting range) can be set using the left-hand switch with detents in the viewing window of the protective housing (see fig. 50).

11.2.5 Operating mode time-dependent lubrication time

In the operating mode time-dependent lubrication time, the lubrication time is determined by the number of incoming cycles of a signal transmitter (e.g. proximity switch of a progressive distributor, see fig. 53). If the integrated control unit does not receive a cycle signal within the adjustable cycle monitoring time of the lubrication time (standard setting 12 min), it indicates an error (see chapter 15.3.2 "Signal indicators EP-tronic").

After the cause of the fault has been eliminated, the fault must be reset by pressing the intermediate lubrication button (see fig. 50).

Depending on the version of the device, the signal transmitter can be connected to the upper Hirschmann plug connection or to the plug connection M12x1 marked in blue (for cycle signal of the distributor, see fig. 50; for connection diagram, see chapter 7.2.6 "Connection diagram for devices with EP-tronic with bayonet plug connection" or chapter 7.2.7 "Connection diagram for devices with EP-tronic with Hirschmann plug connection"). The setting range and the cycle monitoring time of the lubrication time can be changed with the diagnostic software **BEKA-DiSys** (with the version currently stored under www.groeneveld-beka.com).

Fig. 53:

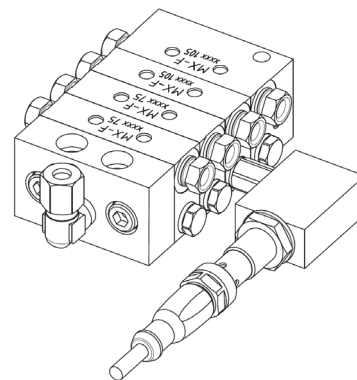
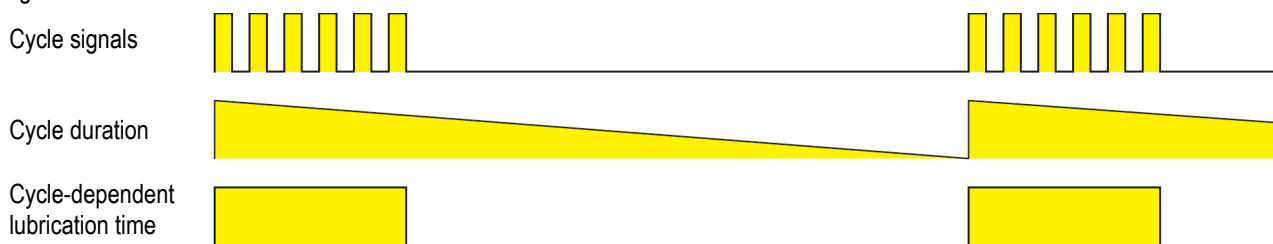

Fig. 54:



Setting ranges of the cycle-dependent lubrication time:

- 1 to 16 cycles (16 detents of 1 cycle each)
- 17 to 32 cycles (16 detents of 1 cycle each)
- 33 to 48 cycles (16 detents of 1 cycle each)

The lubrication time (within a setting range) can be set using the left-hand switch with detents in the viewing window of the protective housing (see fig. 50).

11.2.6 Operating mode rotation-dependent lubrication time

In the rotation-dependent lubrication time operating mode, the lubrication time is determined by the number of pump rotations counted. For this purpose, a sensor is built into the device, which sends a signal to the control unit with each pump rotation. If the control unit does not receive a signal within the adjustable revolution monitoring time (default setting 30 s), it displays an error (see chapter 15.3.2 "Signal indicators EP-tronic").

After the cause of the fault has been eliminated, the fault must be reset by pressing the intermediate lubrication button (see fig. 50). The setting range and the revolution monitoring time can be changed with the diagnostic software **BEKA-DiSys** (with the version currently stored under www.groeneveld-beka.com).

Fig. 55:

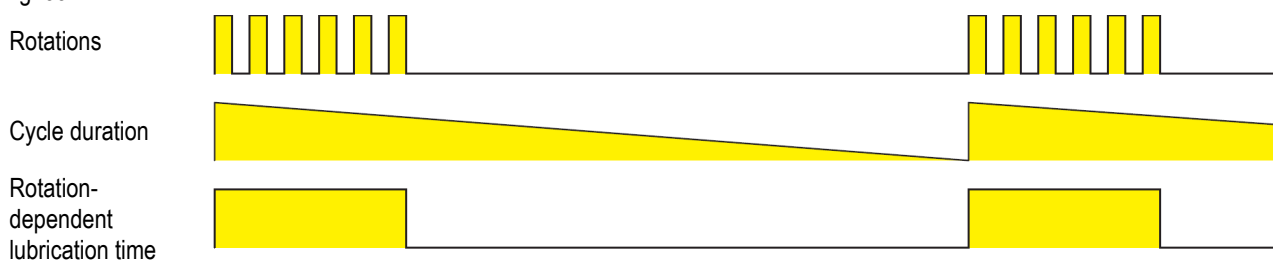

Setting ranges of the rotation-dependent lubrication time:

- 1 to 16 rotations (16 detents of 1 rotation each)
- 10 to 160 rotations (16 detents of 10 rotations each)
- 170 to 320 rotations (16 detents of 10 rotations each)

The lubrication time (within a setting range) can be set using the left-hand switch with detents in the viewing window of the protective housing (see fig. 50).

11.2.7 Level monitoring function

The integrated control unit can evaluate the signal of the level monitoring in the version **MIN level, plug connection M12x1 and voltage range 10 - 60 V DC**. Depending on the version of the device, the level monitoring can be connected to the upper Hirschmann plug connection or to the plug connection M12x1 marked in red (for level monitoring, see fig. 50; for connection diagram, see chapter 7.2.6 "Connection diagram for devices with EP-tronic with bayonet plug connection" or chapter 7.2.7 "Connection diagram for devices with EP-tronic with Hirschmann plug connection").

Further information can be found in chapter 10 "Level monitoring".

Note!

If the function **level monitoring** is not used, the function must be deactivated via the diagnostic software **BEKA-DiSys** (with the version currently stored under www.groeneveld-beka.com). In addition, the existing connection must be closed with a protective cap (item no. 10106213).

11.2.8 System pressure monitoring function

The operating pressure in the lubrication system can be monitored by means of a microswitch fitted to the pressure relief valve (see chapter 9.5.2 "Pressure relief valves with microswitch").

If the pressure in the lubrication system rises above the set value, the pressure relief valve opens and the microswitch is actuated. The microswitch sends a signal to the integrated control unit. This switches off the device and indicates an error (see chapter 15.3.2 "Signal indicators EP-tronic").

After eliminating the cause of the error, the error must be reset by pressing the intermediate lubrication button (see fig. 50).

Depending on the version of the device, the microswitch can be connected to the upper Hirschmann plug connection or to the plug connection M12x1 marked green (for system pressure monitoring, see fig. 50; for connection diagram, see chapter 7.2.6 "Connection diagram for devices with EP-tronic with bayonet plug connection" or chapter 7.2.7 "Connection diagram for devices with EP-tronic with Hirschmann plug connection").

The **system pressure monitoring** function is always active, a microswitch can be connected at any time.

11.2.9 Special function *adaptation to operating conditions*

An adjustment to the operating conditions can be made within the first 30 seconds after switching on the voltage by means of a 3-position key toggle switch (see fig. 56).

The 3-position key toggle switch is not included in the scope of delivery, but can be ordered separately (part no. 10158947).

Fig. 56:



Operating conditions:

Normal - Under normal load, the lubrication points receive lubricant at the set interval (see fig. 57).

Fig. 57:



Light - With light loads, the lubrication points receive lubricant at longer intervals (see fig. 58).

Fig. 58:



Heavy duty - At high loads, the lubrication points receive lubricant at shorter intervals (see fig. 59)

Fig. 59:



After actuating the 3-position key toggle switch, either the voltage (ignition) must be switched off and on again or an intermediate lubrication must be triggered at the intermediate lubrication button (see fig. 50).

11.2.10 Special function *cycle locked*

If the white and the grey wire of the control unit (see chapter 7.4.6 "Connection diagram for devices with EP-tronic with bayonet plug connection and chapter 7.4.7 "Connection diagram for devices with EP-tronic with Hirschmann plug connection) are connected to the ignition, the special function *cycle locked* can be used. This can be done, for example, by a circuit in the vehicle's on-board computer or by an external control.

By closing the circuit by the on-board computer or the external control, the cycle duration is locked or the current lubrication time is completed and the subsequent cycle duration is locked. The green LED in the viewing window of the control unit starts flashing (see chapter 15.3.2 "Signal indicators EP-tronic").

Note!

The flashing signal is not displayed on externally connected signal lamps.

This special function is suitable for applications where machine parts or attachments only need to be lubricated when they are in operation, such as a compactor on a garbage truck.

Note!

If the special function *cycle locked* is used, the 3-position key toggle switch for the special function *adaptation to operating conditions* cannot be connected.

11.2.11 Special function *external status signal*

With the integrated control unit, a status signal can be output either as an **error signal** (default setting) or as an **OK signal** .

With the setting **error signal**, a permanent signal is output when an error is present.

With the **OK signal** setting, a permanent signal is output which is interrupted when an error occurs.

The signals can be evaluated e.g. via a relay or a lamp.

Messages:

- Cycle error during the lubrication time
- Rotation error during the lubrication time
- Reservoir empty
- System pressure too high

The component (e.g. relay or lamp) for evaluating the signals can be connected to the lower Hirschmann plug connection or to the plug connection M12x1 marked yellow (for external status signal, see fig. 50), depending on the version of the device. The component and the connection cable etc. are not included in the scope of delivery.

The integrated control unit is supplied with the **error signal setting as standard**.

If the **setting OK signal** is required, this can be **specified** directly in the **order** or changed with the diagnostic software **BEKA-DiSys** (with the version currently stored at www.groeneveld-beka.com).

11.3 EP-tronic T1

With the integrated control unit EP-tronic T1 the **cycle duration** and the **lubrication time** are determined **time-dependently**.

The integrated control unit EP-tronic T1 is particularly suitable for controlling devices that are mounted on vehicles without a permanent voltage connection (e.g. trailers or semi-trailers).

Signal indicators:

- Functional readiness
- Lubrication running
- Test lubrication running

Operational database:

The integrated control unit has an operating database in which the following values are stored:

- Data of the control unit (type, version, serial number, production date)
- Current settings (cycle duration, lubrication time)
- Statistical values (operating hours, running time of the device, number of intermediate lubrications, number of total diagnoses, etc.)
- Date and time of the last diagnosis

Note!

The setting ranges of the cycle duration and lubrication time can be changed at any time with the diagnostic software **BEKA-DiSys** (with the version currently stored under www.groeneveld-beka.com).

11.3.1 Function description

Fig. 60:

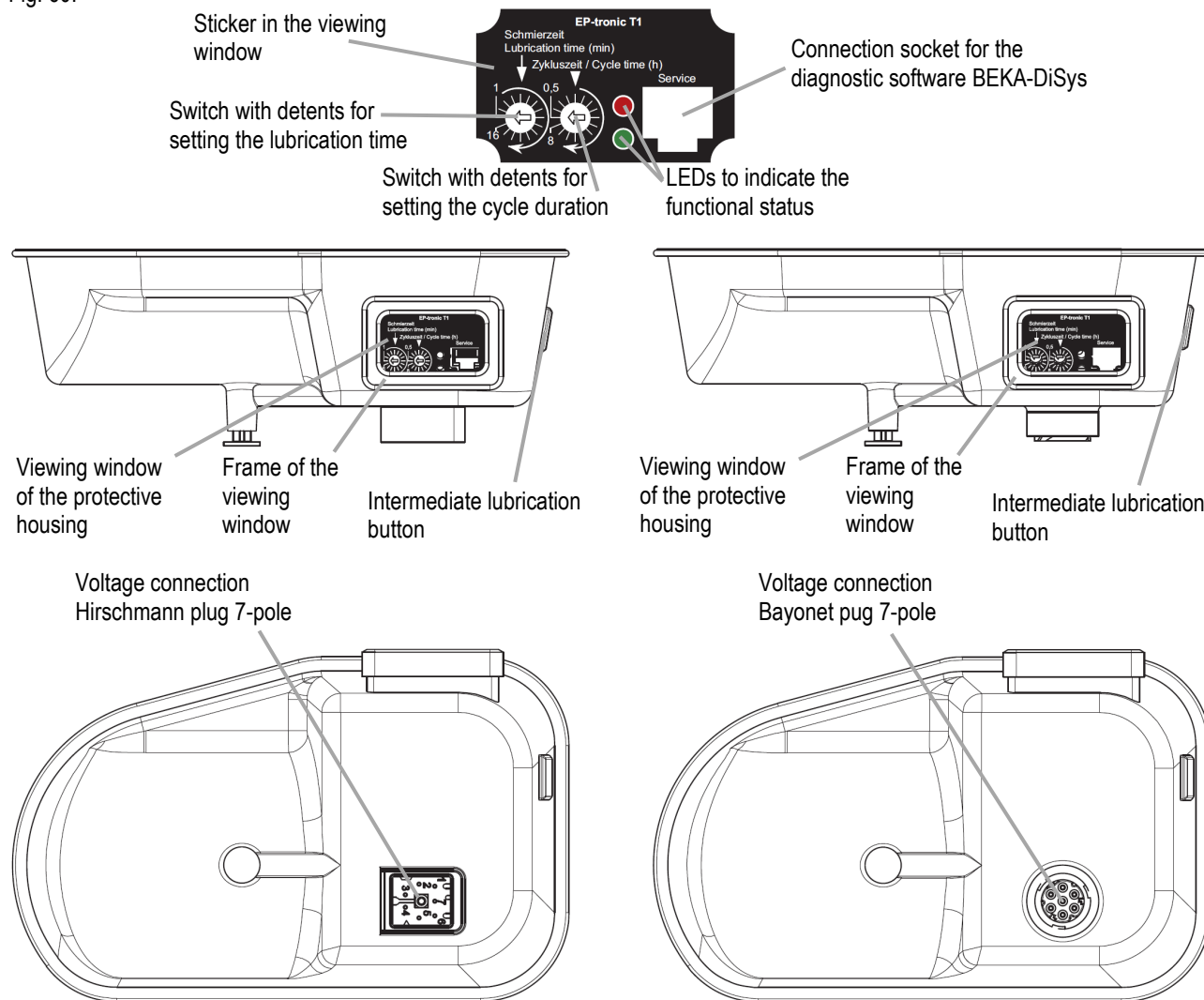

Lubrication starts when the integrated control unit is connected for the first time. Each time the voltage is switched on (ignition), the red and green LEDs in the viewing window of the protective housing light up for approx. 1.5 seconds, indicating that the integrated control unit is ready for operation. If the voltage is interrupted during the cycle duration or during the lubrication time, the data is stored in the operating database of the integrated control unit. When the voltage is switched on again, the cycle starts where it was interrupted before. When the voltage is switched on, intermediate lubrication can be triggered at any time by pressing the intermediate lubrication button. The current cycle data is deleted and a new lubrication cycle starts immediately. There are five voltage inputs on the control unit, three of which (tail light, brake light and possibly rotating beacon; see chapter 7.2.7 "Connection diagram for devices with EP-tronic T1 with bayonet plug connection" or chapter 7.2.8 "Connection diagram for devices with EP-tronic T1 with Hirschmann plug connection") are used to supply power to the device. All five voltage inputs are also used to detect vehicle movement. The device can only deliver lubricant if one of the three inputs is supplied with voltage.

10177337

BAL_EP-1_FKGGM-EP_1221DE_EN_FR_IT_ES

11.3.2 Changing and setting the parameters

The setting ranges of the lubrication time and the cycle duration can be changed at any time with the diagnostic software **BEKA-DiSys** (with the current version stored under www.groeneveld-beka.com).

If the parameters are changed, the sticker in the viewing window of the protective housing must be changed accordingly.

The stickers for the viewing window can be ordered as required:

		Time-dependent cycle duration		
		0,5 - 8 h	2 - 32 min	2 - 32 h
Time-dependent lubrication time				
I	1 - 16 min	10136922	upon request	upon request
II	2 - 32 min	upon request	upon request	upon request
III	2 - 32 s	upon request	10154816	upon request

Within a setting range, the lubrication time and the cycle duration can be changed with a flat screwdriver at the switches with detents in the viewing window of the protective housing (see fig. 60).

To do this, remove the frame on the viewing window of the protective housing using a flat screwdriver, unscrew the four recessed-head screws and remove the transparent viewing window.

Attention!

After setting the parameters, the viewing window and frame must be **closed** again **properly**, otherwise **water** may **enter** the integrated control unit and **destroy** it!

11.3.3 Operating mode time-dependent cycle duration

In the time-dependent cycle duration operating mode, the cycle duration can be set in hours or minutes, depending on the selected setting range. The setting range can be changed with the diagnostic software **BEKA-DiSys** (with the current version stored under www.groeneveld-beka.com).

Fig. 61:

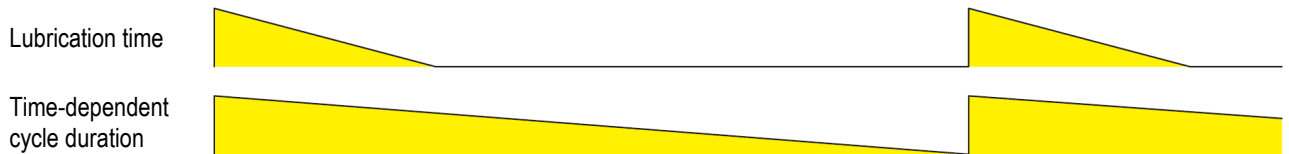

Setting ranges of the time-dependent cycle duration:

- 0.5 to 8 h (16 detents of 0.5 h each)
- 2 to 32 min (16 detents of 2 min each)
- 2 to 32 h (16 detents of 2 h each)

The cycle duration (within a setting range) can be set with the right-hand switch with detents in the viewing window of the protective housing (see fig. 60).

11.3.4 Operating mode time-dependent lubrication time

In the time-dependent lubrication time operating mode, the lubrication time can be set in minutes or seconds, depending on the selected setting range. The setting range can be changed with the diagnostic software **BEKA-DiSys** (with the current version stored under www.groeneveld-beka.com).

Fig. 62:



10177337

BAL_EP-1_FKGGM-EP_1221DE_EN_FR_IT_ES

Setting ranges of the time-dependent lubrication time:

- 1 to 16 min (16 detents of 1 min each)
- 2 to 32 min (16 detents of 2 min each)
- 2 to 32 s (16 detents of 2 s each)

The lubrication time (within a setting range) can be set using the left-hand switch with detents in the viewing window of the protective housing (see fig. 60).

Since the voltage is not permanently present, the set total lubrication time can be made up of several short lubrication times (see fig. 63).

Fig. 63:

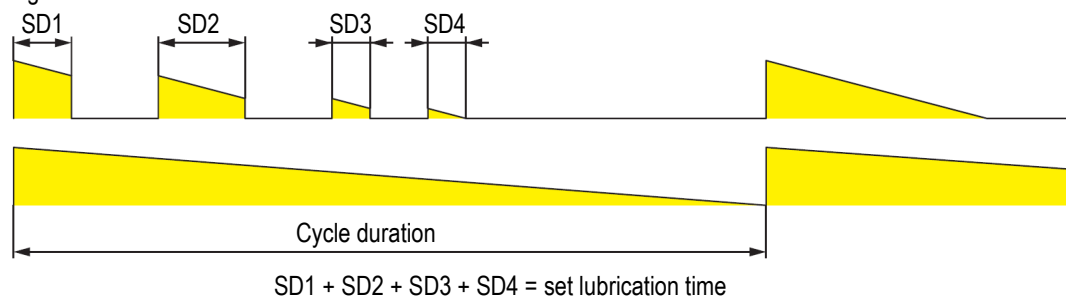

If the lubrication time is not processed within a cycle duration, the remaining lubrication time is transferred to the next cycle. The lubrication time can be summed up to a maximum of double.

If no voltage is applied to any of the five voltage inputs within 30 minutes, the cycle duration is stopped. The control unit assumes that the vehicle to be lubricated is no longer moving.

11.4 EP-T2

With the EP-T2 integrated control unit, the **lubrication time** is determined **time-dependently**.

The EP-T2 integrated control unit is particularly suitable for controlling devices mounted on vehicles without a permanent voltage connection (e.g. trailers or semi-trailers).

11.4.1 Function description

Fig. 64:

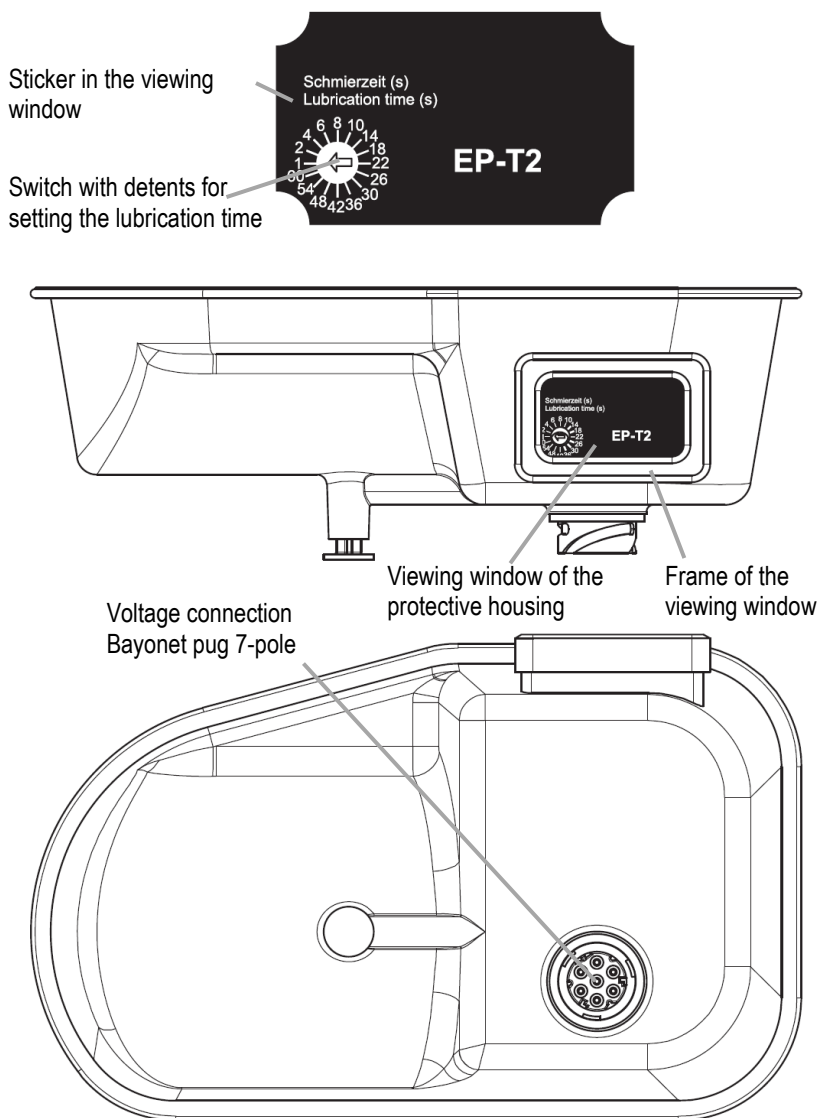

With the EP-T2 integrated control unit, the brake light of the vehicle to be lubricated serves as the power supply. The device can only deliver when the brake light is supplied with voltage, i.e. when the driver brakes. Lubrication starts with every braking process. After the lubrication process, the device is switched off.

11.4.2 Setting the parameters

The lubrication time can be changed with a flat screwdriver on the switch with detents in the viewing window of the protective housing (see fig. 64).

To do this, remove the frame on the viewing window of the protective housing using a flat screwdriver, unscrew the four recessed-head screws and remove the transparent viewing window.

Attention!

After setting the parameters, the viewing window and frame must be **closed** again **properly**, otherwise **water** may **enter** the integrated control unit and **destroy** it!

11.4.3 Operating mode time-dependent lubrication time

In the lubrication time operating mode, the lubrication time can be set in seconds.

Lubrication starts with the set lubrication time for each braking process. After the lubrication time has expired, the device is switched off until the next lubrication process.

Fig. 65:

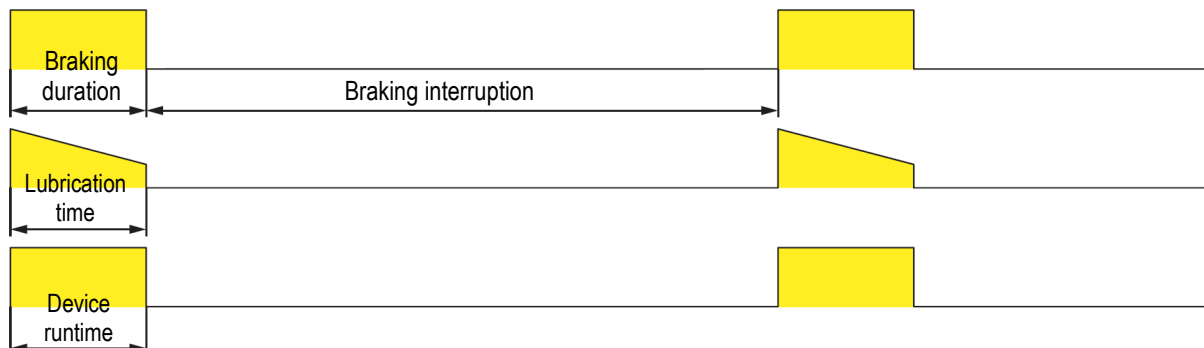

After the lubrication time has expired, the device is switched off, even if the braking process continues beyond the lubrication time.

Fig. 66:

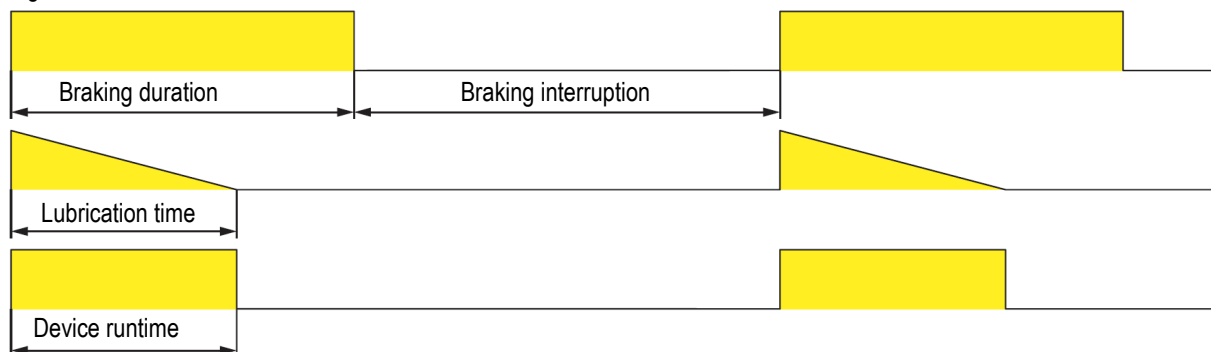

A short interruption of the braking process (< 1s) is ignored by the integrated control unit.

Fig. 67:

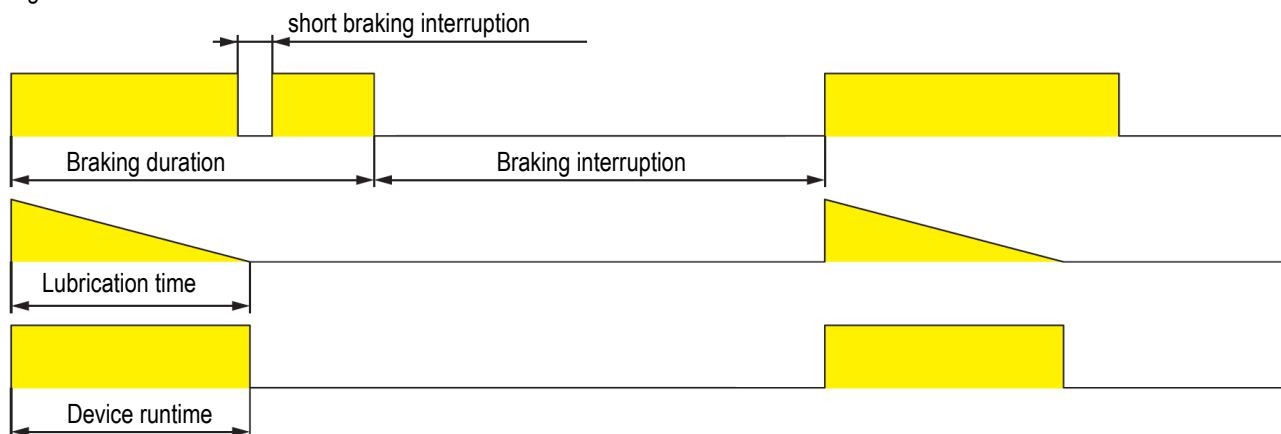

Setting values of the time-dependent lubrication time:

- 1 s, 2 s
- 4 s, 6 s, 8 s, 10 s
- 14 s, 18 s, 22 s, 26 s, 30 s
- 36 s, 42 s, 48 s, 54 s, 60 s

The lubrication time can be set with the switch with detents in the viewing window of the protective housing (see fig. 64).

10177337

BAL_EP-1_FKGM-EP_1221DE_EN_FR_IT_ES

12. Maintenance



Before carrying out **maintenance and repair work**, the **device** must be **disconnected from the power** supply. All **maintenance and repair work** must be carried out with the device at a **complete standstill** and in a **depressurised state**. The surface temperature of the device must be checked, as there is a **risk of burns** due to heat transfer. Wear heat-resistant safety gloves and safety goggles! Dirty or contaminated surfaces must be cleaned before maintenance work is carried out; protective equipment must be worn for this purpose if necessary. Secure the device against restarting during maintenance/repair work!



12.1 General maintenance

- Tighten all screw connections again 6 weeks after commissioning!
- All components must be checked for leaks and damage at least every four weeks!



Leaks that have not been eliminated can cause **lubricant to escape** under **high pressure**. If lubricant puddles have formed due to leakages, these must be removed immediately.

12.2 Lubricant change

Attention!

Always ensure **cleanliness** when **refilling** the **lubricant**!

- Check level regularly, refill with clean lubricant if necessary, as described in chapter 8 "Commissioning"!
- The lubricant must be replaced in accordance with the lubricant manufacturer's specifications. Environmental influences such as increased temperature or contamination can shorten these intervals!
- Please make sure that only lubricants are used which are suitable for the device as well as for the machine to be lubricated and which meet the requirements of the respective operating conditions!
- Make sure that the **quality** of the lubricant corresponds to that of the pre-filled lubricant when using **different lubricant suppliers**! To be on the safe side, the lubricant reservoir should be completely and properly emptied and cleaned even if it is well tolerated!

12.3 Changing the integrated control unit

Installation instructions (part no. 10150959) for changing the integrated control unit are available on request.

13. Decommissioning

- Depressurise the device!
- Switch off electrical power supply!
- Have electrical components disconnected from the electrical power supply by a trained electrician!
- For disassembly, remove all pipe and hose lines from the device and loosen the fastenings!

14. Disposal

Note!

When changing the lubricant, the disposal instructions of the lubricant manufacturer must be observed!

Lubricants or rags or similar contaminated with lubricant must be collected in appropriately marked containers and disposed of properly.

The device must be disposed of properly and professionally in accordance with national and international laws and regulations.

15. Troubleshooting

15.1 Troubleshooting for devices without integrated control unit

Faults	Possible cause	Possible troubleshooting
Device does not work	Fuse defective	Replace fuse
	Electrical line interrupted	Renew electrical line
	Device defective	Renew device
Device works, but does not deliver	Air cushion in the delivery piston	Vent the device
	Air cushion in the reservoir	Vent the device
	Reservoir empty	Fill reservoir
	Pump element defective	Replace pump element
No lubricant collar at all lubrication points	Device does not work	See fault "Device not working"
	Lubrication system blocked	See fault "Lubricant leakage at the pressure relief valve"
No lubricant collar at several lubrication points	Supply lines to secondary distributors burst or leaking	Renew lines
	Screw connections leaky	Retighten or renew screw connections
Speed of the device reduced	High system pressure	Check lubrication system / lubrication points (no damage)
	Supply voltage too low	Check supply voltage
Lubricant leakage at the pressure relief valve	System pressure too high	Check lubrication system
	Progressive distributor blocked	Replace affected progressive distributor
	Lubrication system blocked	Repair clogged / fixed lubrication point
	Valve spring broken	Renew pressure relief valve
Level monitoring sends a signal although the reservoir is full	Level monitoring defective	Renew level monitoring
	Level monitoring incorrectly connected	Check connection of level monitoring, change if necessary

15.2 Troubleshooting for device with integrated control unit

Faults	Possible cause	Possible troubleshooting
Device does not work	Fuse defective	Replace fuse
	Electrical line interrupted	Renew electrical line
	Device defective	Renew device
	Integrated control unit defective	Renew integrated control unit
Device works, but does not deliver	Air cushion in the delivery piston	Vent the device
	Air cushion in the reservoir	Vent the device
	Reservoir empty	Fill reservoir
	Pump element defective	Replace pump element
	Integrated control unit defective	Renew integrated control unit

10177337

BAL_EP-1_FKGGM-EP_1221DE_EN_FR_IT_ES

Faults	Possible cause	Possible troubleshooting
No lubricant collar at all lubrication points	Device does not work	See fault "Device not working"
	Lubrication system blocked	See fault "Lubricant leakage at the pressure relief valve"
	Lubrication time (device running time) too short	Extend lubrication time
	Cycle duration too long	Reduce cycle duration
No lubricant collar at several lubrication points	Supply lines to secondary distributors burst or leaking	Renew lines
	Screw connections leaky	Retighten or renew screw connections
Speed of the device reduced	High system pressure	Check lubrication system / lubrication points (no damage)
	Supply voltage too low	Check supply voltage
Lubricant leakage at the pressure relief valve	System pressure too high	Check lubrication system
	Progressive distributor blocked	Replace affected progressive distributor
	Lubrication system blocked	Repair clogged / fixed lubrication point
	Valve spring broken	Renew pressure relief valve
Level monitoring sends a signal although the reservoir is full	Level monitoring defective	Renew level monitoring
	Level monitoring incorrectly connected	Check connection of level monitoring, change if necessary
Error <i>level too low</i> is displayed, although no level monitoring is installed	Level monitoring is activated in the integrated control unit	Deactivate level monitoring in the control with the help of the diagnostic software BEKA-DiSys
LEDs in the viewing window of the integrated control unit flash (see chapter 15.3 "Signal indicators of the integrated control unit")	Device works	No fault
	Cycle error in operating mode time-dependent lubrication time	Check external signal transmitter and connected cable, replace if necessary Reset error with intermediate lubrication
	Error <i>level too low</i>	Fill reservoir
	Error <i>system pressure too high</i>	Check lubrication system, repair if necessary Reset error with intermediate lubrication
	Rotation error in operating mode rotation-dependent lubrication time	Check lubrication system or device, repair if necessary Reset error with intermediate lubrication
The functions of the device (operating mode, cycle duration or lubrication time) do not match the values set on the integrated control unit	The operating mode or the setting range of the integrated control unit has been changed, but the sticker in the viewing window of the protective housing has not been changed	Create a diagnosis with the diagnostic software BEKA-DiSys and adjust the settings accordingly or exchange the sticker in the viewing window.

15.3 Signal indicators of the integrated control unit

With the integrated control units BEKA-troniX1, EP-tronic and EP-tronic T1 the functions of the device are displayed via two LEDs (green and red) in the viewing window of the protective housing, whereby the red LED always indicates an error in the program sequence.

The functions of the device can also be displayed via externally installed signal lamps, but these must be ordered separately (part no. on request).

If several errors occur simultaneously, they are displayed one after the other with a pause of approx. 2 seconds.

15.3.1 Signal indicators BEKA-troniX1

Signal indicators	Function
<p>Ready for operation 1.5 s</p> <p>LED red: ON (red bar), OFF (line)</p> <p>LED green: ON (green bar), OFF (line)</p>	Indication of functional readiness after the voltage is switched on for the first time
<p>During the entire lubrication</p> <p>LED red: ON (line), OFF (line)</p> <p>LED green: ON (green bar), OFF (line)</p>	One lubrication procedure
<p>Until lubricant is refilled</p> <p>LED red: ON (red bar), OFF (line)</p> <p>LED green: ON (line), OFF (line)</p>	Error level too low
<p>1 s 1 s</p> <p>LED red: ON (pulsed red bars), OFF (line)</p> <p>LED green: ON (green bar), OFF (line)</p>	Error system pressure too high
<p>1 s 1 s</p> <p>LED red: ON (pulsed red bars), OFF (line)</p> <p>LED green: ON (line), OFF (line)</p>	Rotation error in operating mode rotation-dependent lubrication time
<p>0.5 s 0.5 s</p> <p>LED red: ON (pulsed red bars), OFF (line)</p> <p>LED green: ON (line), OFF (line)</p>	Error CPU/memory
<p>1 s 1 s</p> <p>LED red: ON (pulsed red bars), OFF (line)</p> <p>LED green: ON (pulsed green bars), OFF (line)</p>	Test lubrication (permanent lubrication) In order to initiate continuous lubrication for service purposes in the operating mode time-dependent lubrication time, the lubrication time must be set higher than the cycle duration.

10177337

BAL_EP-1_FKGGM-EP_1221DE_EN_FR_IT_ES

15.3.2 Signal indicators EP-tronic

Signal indicators	Function
<p>Ready for operation 1.5 s</p> <p>LED red: ON (red bar), OFF (line)</p> <p>LED green: ON (green bar), OFF (line)</p>	Indication of functional readiness after the voltage is switched on for the first time
<p>During the entire lubrication</p> <p>LED red: ON (line), OFF (line)</p> <p>LED green: ON (green bar), OFF (line)</p>	One lubrication procedure
<p>LED red: ON (pulsed red bars), OFF (line)</p> <p>LED green: ON (pulsed green bars), OFF (line)</p> <p>1 s, 1 s</p>	Cycle error in operating mode time-dependent lubrication time
<p>Until lubricant is refilled</p> <p>LED red: ON (red bar), OFF (line)</p> <p>LED green: ON (line), OFF (line)</p>	Error level too low
<p>LED red: ON (pulsed red bars), OFF (line)</p> <p>LED green: ON (solid green bar), OFF (line)</p> <p>1 s, 1 s</p>	Error system pressure too high
<p>LED red: ON (pulsed red bars), OFF (line)</p> <p>LED green: ON (line), OFF (line)</p> <p>1 s, 1 s</p>	Rotation error in operating mode rotation-dependent lubrication time
<p>LED red: ON (pulsed red bars), OFF (line)</p> <p>LED green: ON (line), OFF (line)</p> <p>0.5 s, 0.5 s</p>	Error CPU/memory

10177337

BAL_EP-1_FKGGM-EP_1221DE_EN_FR_IT_ES

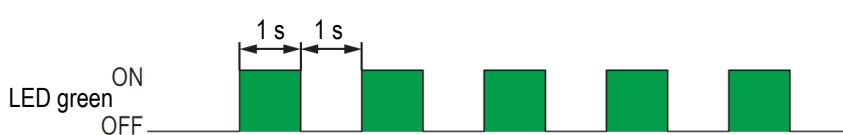
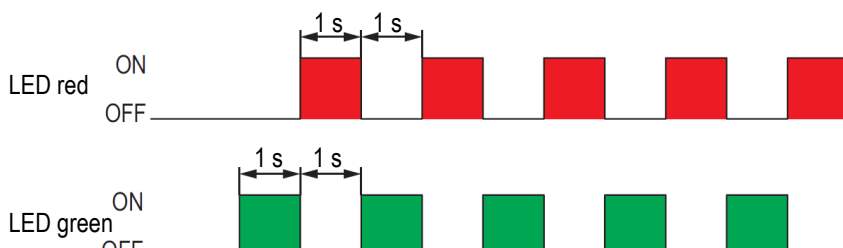
Signal indicators	Function
<p>LED red ON</p> <p>LED red OFF</p> 	Cycle locked
<p>LED red ON</p> <p>LED red OFF</p> 	<p>Test lubrication (permanent lubrication)</p> <p>In order to initiate continuous lubrication for service purposes in the operating mode time-dependent lubrication time, the lubrication time must be set higher than the cycle duration.</p>

15.3.3 Signal indicators EP-tronic T1

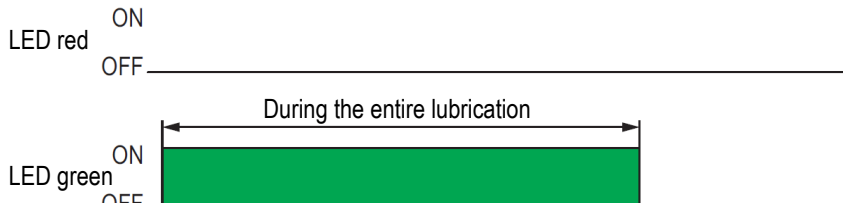
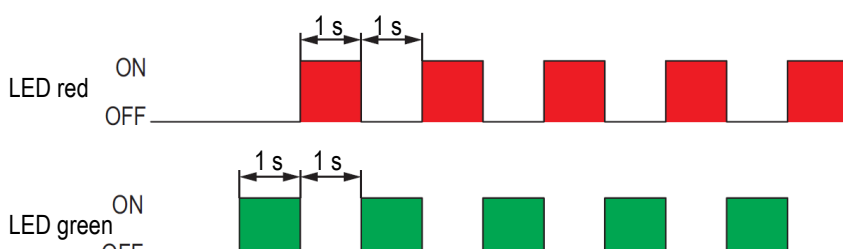
Signal indicators	Function
<p>LED red ON</p> <p>LED red OFF</p> <p>Ready for operation 1.5 s</p> 	Indication of functional readiness after the voltage is switched on for the first time
<p>LED red ON</p> <p>LED red OFF</p> <p>During the entire lubrication</p> 	One lubrication procedure
<p>LED red ON</p> <p>LED red OFF</p> 	<p>Test lubrication (permanent lubrication)</p> <p>In order to initiate continuous lubrication for service purposes in the operating mode time-dependent lubrication time, the lubrication time must be set higher than the cycle duration.</p>

10177337

BAL_EP-1_FKGGM-EP_1221DE_EN_FR_IT_ES

16. Code

16.1 Code for devices FKGGM-EP without control unit 2018

Type no.	2018				2018		X	X	XX	XX	000
Code	2018										
Drive type	DC motor without power supply device			12 V DC	24 V DC						
Code				1	2						
Pump element**	PE 120	PE 120 with DBV*	PE 120 V	PE 120 V with DBV*							
Code	0	1	2	4							
Pressure connections	Outlet number										
Outlet type	1	2	3								
Pipe Ø6 mm	01	02	03								
Pipe Ø8 mm	11	12	13								
Pipe Ø10 mm	21	22	23								
Thread G1/4	31	32	33								
Reservoir capacity (l)	1.9	2.5	4	8 (2-piece)	8 (1-piece)						
without FÜ***	without filler cap		08	01	04	05	09				
with FÜ*** (M12x1 standard)	without filler cap		-	D1	D2	-	D3				
with FÜ***	without filler cap		-	F1	F2	-	F3				
without FÜ*** (cable socket****)	with filler cap		-	21	41	42	43				
with FÜ*** (M12x1 standard)	with filler cap		-	E1	E2	-	E3				
with FÜ*** (cable socket ****)	with filler cap		-	G1	G2	-	G3				
Special versions											

* with DBV = with pressure relief valve

** Please specify pump elements PE 60 and PE 170 separately, see chapter 9.4 "Pump elements"

*** FÜ = level monitoring (MIN)

**** Cable socket according to EN 175301-803 A

10177337

BAL_EP-1_FKGGM-EP_1221DE_EN_FR_IT_ES

16.2 Code for devices FKGGM-EP without control unit type 2037

Type no.	2037		2037					X	X	X	X	X	XX	000
Code	2037													
Drive type	DC motor with power supply device		24 V DC / 230 V AC		24 V DC / 115 V AC									
Code			1		2									
Pump element 1**	PE 120 / PE 170 / PE 120 V (all PE* without or with DBV*)													
Code / letter	1 - 7** or A - O**, Z = version without pump element													
Pump element 2**	PE 120 / PE 170 / PE 120 V (all PE* without or with DBV*)													
Code / letter	1 - 7** or A - O**, Z = version without pump element													
Pump element 3**	PE 120 / PE 170 / PE 120 V (all PE* without or with DBV*)													
Code / letter	1 - 7** or A - O**, Z = version without pump element													
Filling connection	Conical lubrication nipple G1/4			Filling connection G1/4										
Code	1			2										
Reservoir capacity (l)			1.9	2.5	4	8 (2-piece)	8 (1-piece)							
without FÜ***	without filler cap		02	01	03	04	07							
with FÜ*** (M12x1 standard)	without filler cap		-	D1	D2	-	D3							
with FÜ***	without filler cap		-	F1	F2	-	F3							
without FÜ***	(cable socket****)		with filler cap	-	21	23	24	25						
with FÜ*** (M12x1 standard)	with filler cap		-	E1	E2	-	E3							
with FÜ*** (cable socket****)	with filler cap		-	G1	G2	-	G3							
Special versions														

- * PE = Pump element(s); DBV = Pressure relief valve
- ** Please specify pump elements PE 60 separately, see chapter 9.4 "Pump elements"
- *** FÜ = level monitoring (MIN)
- **** Cable socket according to EN 175301-803 A

10177337

BAL_EP-1_FKGGM-EP_1221DE_EN_FR_IT_ES

16.3 Code for devices EP-1 without control unit type 2152

Type no.	2152
Code	2152

2152 XX XX XX 000

Motor voltage	without plug connection		with bayonet plug connection	
Voltage	12 V DC	24 V DC	12 V DC	24 V DC
Code	01	02	03	04

Pump elements	Outlet number		
	1	2	3
without	0	0	0
PE 60	1	1	1
PE 120	2	2	2
PE 120 V	3	3	3
PE 170	4	4	4

Example code for pump elements

1x PE 120 installed in outlet position 1:

Outlet position	1	2	3
Number	2	0	0
Code	01		

Number	Code	Number	Code	Number	Code	Number	Code	Number	Code
000	00	100	F0	200	01	300	41	400	V0
001	A1	101	F1	201	K1	301	Q1	401	V1
002	A3	102	F2	202	K2	302	Q2	402	V2
003	A4	103	F3	203	K3	303	Q3	403	V3
004	A5	104	F4	204	K4	304	Q4	404	V4
010	B0	110	N0	210	L0	310	R0	410	W0
011	B1	111	G1	211	L1	311	R1	411	W1
012	B2	112	G2	212	L2	312	R2	412	W2
013	B3	113	G3	213	L3	313	R3	413	W3
014	B4	114	G4	214	L4	314	R4	414	W4
020	C0	120	H0	220	02	320	S0	420	X0
021	C1	121	H1	221	M1	321	S1	421	X1
022	C2	122	H2	222	03	322	S2	422	X2
023	C3	123	H3	223	M3	323	S3	423	X3
024	C4	124	H4	224	M4	324	S4	424	X4
030	D0	130	H5	230	52	330	42	430	Y0
031	D1	131	H6	231	N1	331	T1	431	Y1
032	D2	132	H7	232	N2	332	T2	432	Y2
033	D3	133	H8	233	53	333	43	433	Y3
034	D4	134	H9	234	N4	334	T4	434	Y4
040	E0	140	J0	240	P0	340	U0	440	Z0
041	E1	141	J1	241	P1	341	U1	441	Z1
042	E2	142	J2	242	P2	342	U2	442	Z2
043	E3	143	J3	243	P3	343	U3	443	Z3
044	E4	144	J4	244	P4	344	U4	444	Z4

Reservoir capacity (l)	1.9	2.5	4	8	16
without level monitoring	27	25	30	35	37
with level monitoring (connection plug M12x1 MIN)	-	51	52	53	-

Special versions

 10177337
 BAL_EP-1_FKGM-EP_1221DE_EN_FR_IT_ES

16.4 Code for devices EP-1 with BEKA-troniX1 type 2175

Type no.	2175		2175 X X X X X X X 000						
Code	2175								
Motor voltage with bayonet plug connection									
Voltage	12 V DC	24 V DC							
Code	3	4							
Outlet	Pump element	without	PE 60	PE 120	PE 120 V	PE 170			
Pos. 1	without microswitch	0	7	1	2	G			
	with microswitch	0	A	D	N	H			
Pos. 2	without microswitch	0	8	3	4	J			
	with microswitch	0	B	E	P	K			
Pos. 3	without microswitch	0	9	5	6	L			
	with microswitch	0	C	F	Q	M			
Special versions		ZZZ							
Reservoir capacity (l)			1.9	2.5	4	8	16		
without level monitoring			1	4	2	8	9		
with level monitoring (connection plug M12x1 MIN)			-	A	B	C	-		
Additional equipment									
Without connection plug for additional equipment								0	
Level monitoring								1	
System pressure monitoring								2	
Level monitoring and system pressure monitoring								3	
Without connection to the control unit (Connection plug present, not connected, not activated)								4	
Parameter			Time-dependent cycle duration						
			0,5 - 8 h	2 - 32 min	2 - 32 h				
Time-dependent lubrication time	1 - 16 min		1	A	J				
	2 - 32 min		2	B	K				
	2 - 32 s		3	C	L				
Rotation-dependent lubrication time	1 - 16 rot.		7	G	O				
	10 - 160 rot.		8	H	Q				
	170 - 320 rot.		9	I	R				
Special versions									

10177337

BAL_EP-1_FKGGM-EP_1221DE_EN_FR_IT_ES

16.5 Code for devices EP-1 with EP-tronic type 2157

Type no.	2157
Code	2157

2157 X X X X X X 0000

Motor voltage	with Hirschmann plug connection		with bayonet plug connection	
Voltage	12 V DC	24 V DC	12 V DC	24 V DC
Code	1	2	3	4

Pump elements	Outlet number		
	1	2	3
without	0	0	0
PE 60	1	1	1
PE 120	2	2	2
PE 120 V	3	3	3
PE 170	4	4	4

Example code for pump elements

1x PE 120 installed in outlet position 1:

Outlet position 1 2 3

Number 2 0 0

Code 4

see next page

Number	Code	Number	Code	Number	Code	Number	Code
001	G	002	K	003	N	004	R
010	H	020	L	030	P	040	S
011	J	022	M	033	Q	044	T
100	1	200	4	300	V	400	D
110	2	220	5	330	B	440	E
111	3	222	6	333	C	444	F
120	7	021	9	122	8	123	U
102	W	Special version					Z

Reservoir capacity (l)	1.9	2.5	4	8	16
without level monitoring	1	4	2	8	K
with level monitoring (connection plug M12x1 MIN)	-	N	M	P	-

Additional functions	
Without connection to the control unit (Connection plug present, not connected, not activated)	0
System pressure monitoring	1
Level monitoring	2
Level monitoring and system pressure monitoring	3

Parameter		Time-dependent cycle duration		
		0,5 - 8 h	2 - 32 min	2 - 32 h
Time-dependent lubrication time	1 - 16 min	1	A	J
	2 - 32 min	2	B	K
	2 - 32 s	3	C	L
Cycle-dependent lubrication time	1 - 16 cycles	4	D	M
	17 - 32 cycles	5	E	N
	33 - 48 cycles	6	F	O
Rotation-dependent lubrication time	1 - 16 rot.	7	G	P
	10 - 160 rot.	8	H	Q
	170 - 320 rot.	9	I	R

10177337

BAL_EP-1_FKGM-EP_1221DE_EN_FR_IT_ES

2157 X X X X X X 0000

External status signal	as error signal	as OK signal
Code	1	2

Special versions

16.6 Code for devices EP-1 with EP-tronic T1 type 2183

2183 X X X X X 0000

Type no.	2183
Code	2183

Motor voltage	with Hirschmann plug connection		with bayonet plug connection	
Voltage	12 V DC	24 V DC	12 V DC	24 V DC
Code	1	2	3	4

Pump elements	Outlet number		
	1	2	3
without	0	0	0
PE 60	1	1	1
PE 120	2	2	2
PE 120 V	3	3	3
PE 170	4	4	4

Example code for pump elements
 1x PE 120 installed in outlet position 1:
 Outlet position 1 2 3
 Number 2 0 0
 Code 4

Number	Code	Number	Code	Number	Code	Number	Code	
001	G	002	K	003	N	004	R	
010	H	020	L	030	P	040	S	
011	J	022	M	033	Q	044	T	
100	1	200	4	300	V	400	D	
110	2	220	5	330	B	440	E	
111	3	222	6	333	C	444	F	
120	7	021	9	122	8	123	U	
102	W	Special version						Z

Reservoir capacity (l)	1.9	2.5	4	8
Code	1	4	2	8

Parameter		Time-dependent cycle duration		
		0,5 - 8 h	2 - 32 min	2 - 32 h
Time-dependent lubrication time	1 - 16 min	1	A	J
	2 - 32 min	2	B	K
	2 - 32 s	3	C	L

Intermediate lubrication button	witho ut	wit h
Code	0	1

Special versions

10177337

BAL_EP-1_FKGGM-EP_1221DE_EN_FR_IT_ES

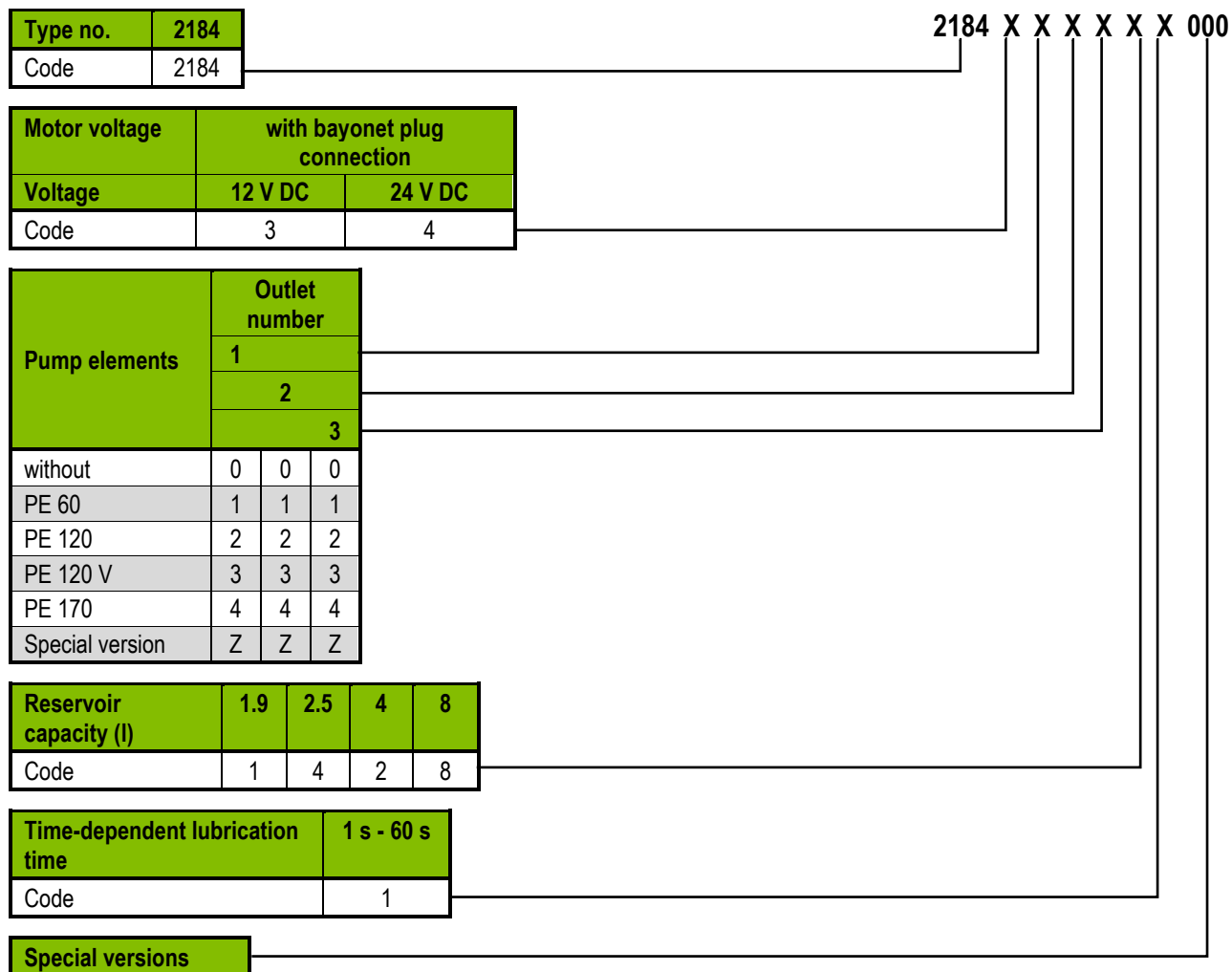
16.7 Code for devices EP-1 with EP-T2 Type 2184

10177337

BAL_EP-1_FKGGM-EP_1221DE_EN_FR_IT_ES

16.8 Code for control units

Note!

The following codes refer to the protective housing with the respective integrated control unit. They are intended for replacement or retrofit needs only.

16.8.1 Code for BEKA-troniX1 type 2175

Type no.	2175				2175	90	XX	X	X	000
Code	2175									
Connection*	Bayonet plug connection									
Code	10									
Additional equipment										
Without connection plug for additional equipment					0					
Level monitoring					1					
System pressure monitoring					2					
Level monitoring and system pressure monitoring					3					
Without connection to the control unit (Connection plug present, not connected, not activated)					4					
Parameter		Time-dependent cycle duration								
		0,5 - 8 h		2 - 32 min		2 - 32 h				
Time-dependent lubrication time	1 - 16 min	1		A		J				
	2 - 32 min	2		B		K				
	2 - 32 s	3		C		L				
Rotation-dependent lubrication time	1 - 16 rot.	7		G		O				
	10 - 160 rot.	8		H		Q				
	170 - 320 rot.	9		I		R				
Special versions										

* for 12 and 24 V DC

10177337

BAL_EP-1_FKGGM-EP_1221DE_EN_FR_IT_ES

16.8.2 Code for EP-tronic type 2157

Type no.	2157					2157	90	XX	X	X	X	00
Code	2157											
Connection*	Hirschmann plug connection	Bayonet plug connection										
Code	00	10										
Additional functions												
Without connection to the control unit (Connection plug present, not connected, not activated)										0		
System pressure monitoring										1		
Level monitoring										2		
Level monitoring and system pressure monitoring										3		
Parameter		Time-dependent cycle duration										
		0,5 - 8 h	2 - 32 min	2 - 32 h								
Time-dependent lubrication time	1 - 16 min	1	A	J								
	2 - 32 min	2	B	K								
	2 - 32 s	3	C	L								
Cycle-dependent lubrication time	1 - 16 cycles	4	D	M								
	17 - 32 cycles	5	E	N								
	33 - 48 cycles	6	F	O								
Rotation-dependent lubrication time	1 - 16 rot.	7	G	P								
	10 - 160 rot.	8	H	Q								
	170 - 320 rot.	9	I	R								
External status signal	as error signal	as OK signal										
Code	1	2										
Special versions												

* for 12 and 24 V DC

10177337

BAL_EP-1_FKGGM-EP_1221DE_EN_FR_IT_ES

16.8.3 Code for EP-tronic T1 type 2183

Type no.	2183				2183 90 XX X X 0000	
Code	2183					
Connection*	Hirschmann plug connection	Bayonet plug connection				
Code	00	10				
Parameter	Time-dependent cycle duration					
		0,5 - 8 h	2 - 32 min	2 - 32 h		
	Time-dependent lubrication time	1 - 16 min	1	A	J	
		2 - 32 min	2	B	K	
	2 - 32 s	3	C	L		
Intermediate lubrication button	without	with				
Code	0	1				
Special versions						

* for 12 and 24 V DC

16.8.4 Code for EP-T2 type 2184

Type no.	2184				2184 90 XX X 00000	
Code	2184					
Connection*	Bayonet plug connection					
Code	10					
Time-dependent lubrication time	1 s - 60 s					
Code	1					
Special versions						

17. Spare parts list and drawing

Spare parts lists and drawings are available on request.
Please state the article number of your device.

10177337

BAL_EP-1_FKGGM-EP_1221DE_EN_FR_IT_ES

18. Dimensional drawings

The following dimensional drawings apply to standard versions.
 Dimensional drawings for special versions are available on request. Please state the article number of your device.

18.1 Dimensional drawing for devices with 1.9 l

Fig. 68:

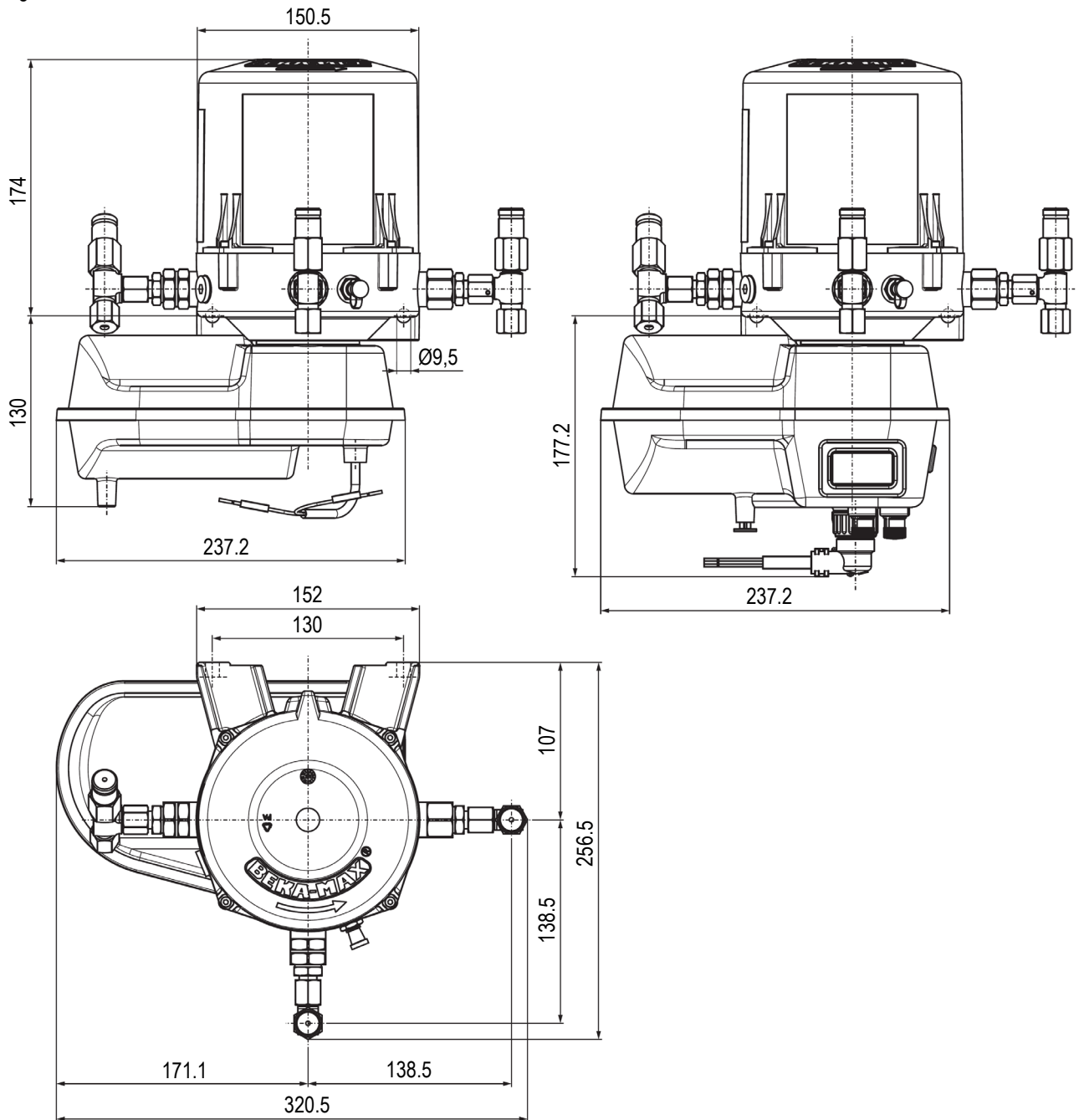

10177337

BAL_EP-1_FKGGM-EP_1221DE_EN_FR_IT_ES

18.2 Dimensional drawing for devices with 2,5 l

Fig. 69:

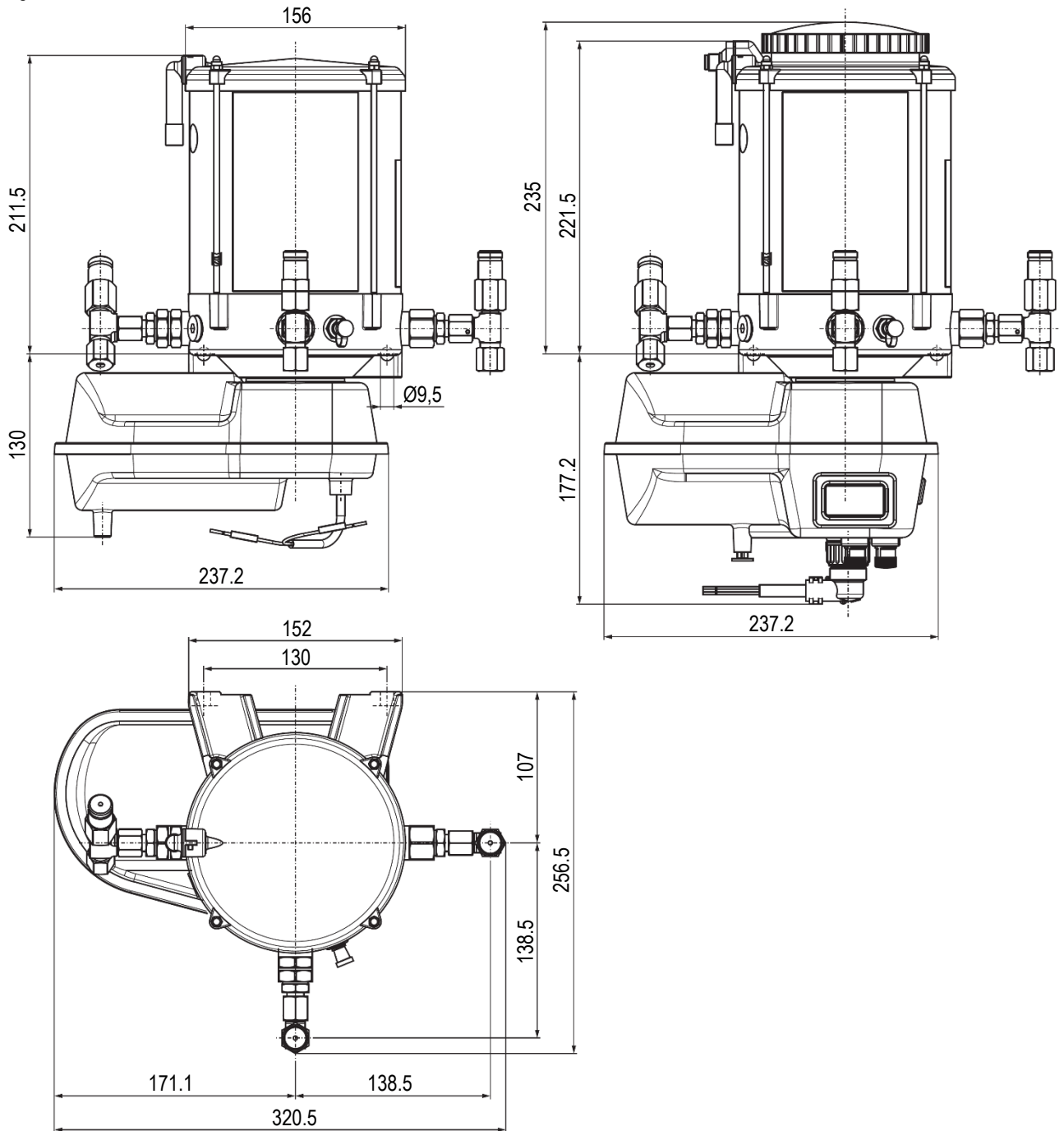

10177337

BAL_EP-1_FKGGM-EP_1221DE_EN_FR_IT_ES

18.3 Dimensional drawing for devices with 4,0 l

Fig. 70:

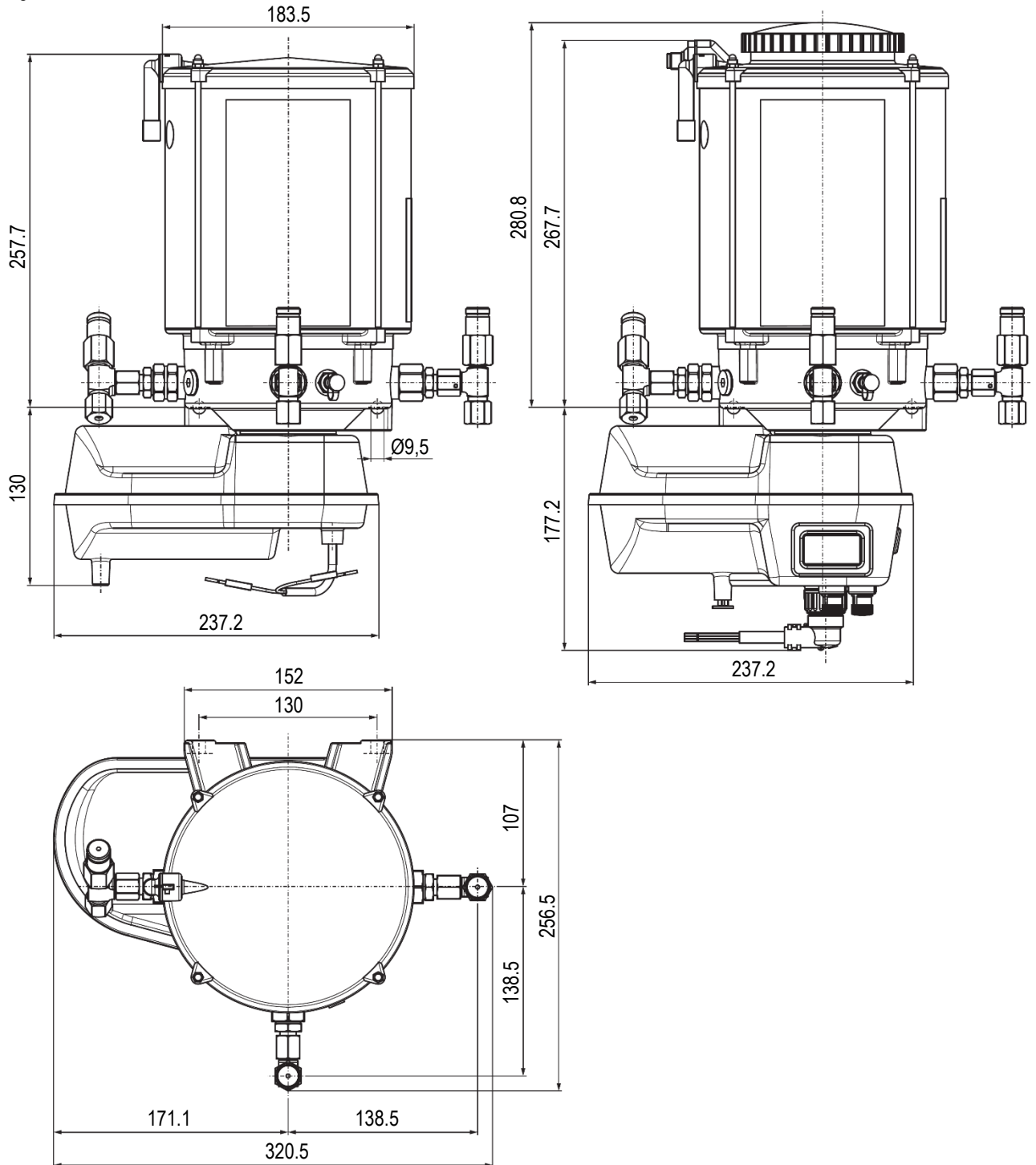

10177337

BAL_EP-1_FKGGM-EP_1221DE_EN_FR_IT_ES

18.4 Dimensional drawing for devices with 8,0 l

Fig. 71:

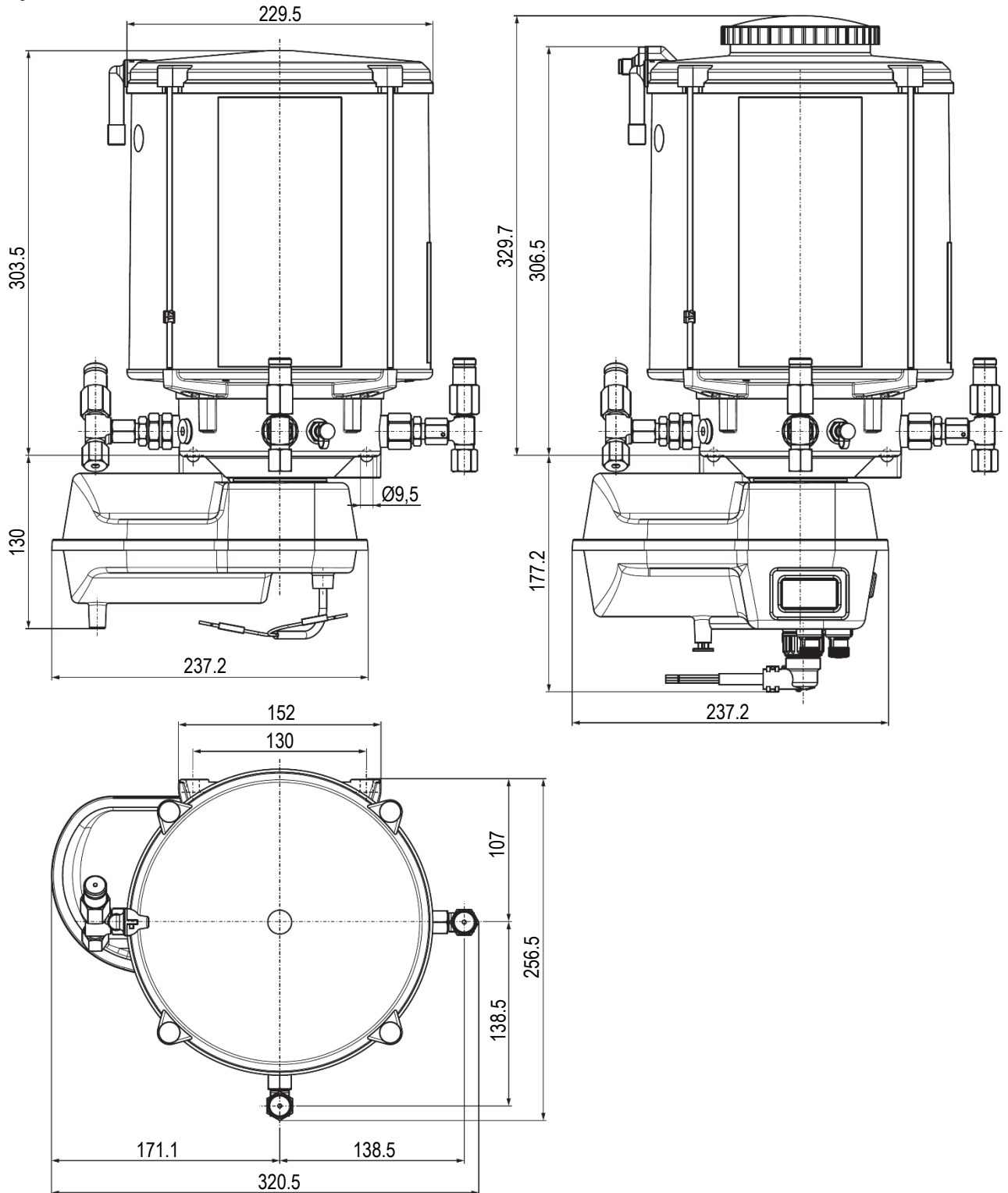

10177337

BAL_EP-1_FKGGM-EP_1221DE_EN_FR_IT_ES

18.5 Dimensional drawing for devices with 16,0 l

Fig. 72:

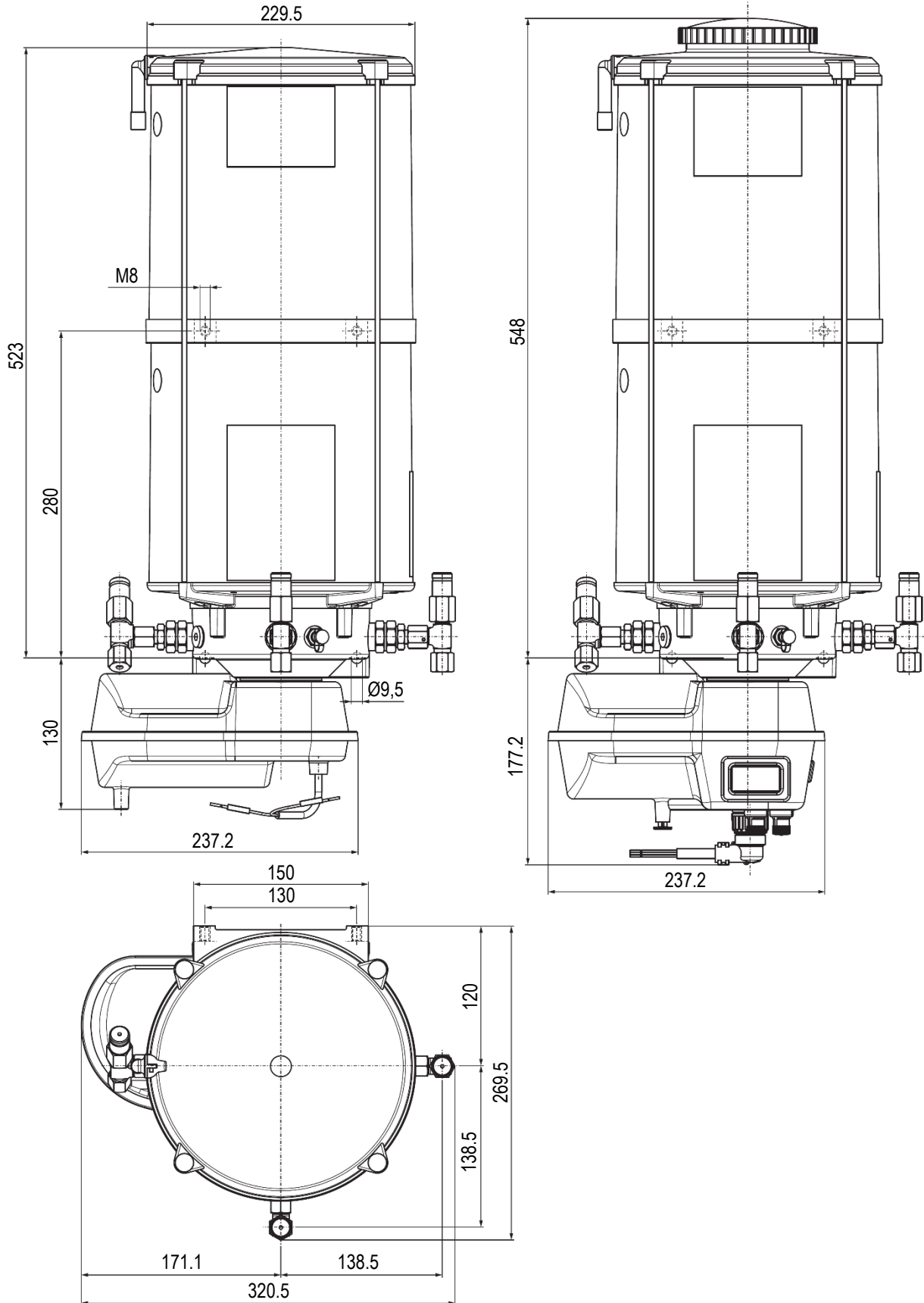

10177337

BAL_EP-1_FKGGM-EP_1221DE_EN_FR_IT_ES

19. Details of the manufacturer

Groeneveld-BEKA GmbH

Beethovenstraße 14
91257 PEGNITZ / Bavaria
Germany

Phone +49 9241 729-0
FAX +49 9241 729-50

POSTFACH 1320
91253 PEGNITZ / Bavaria
Germany

<http://www.groeneveld-beka.com>
Email: info-de@groeneveld-beka.com

Our further delivery program:

Gear pumps
Oil multi-line pumps
Grease multi-line pumps
Single-line central lubrication systems
Dual-line central lubrication systems
Oil circulation central lubrication systems
Oil-air and spray lubrication
Wheel flange central lubrication systems
Rolling mill central lubrication systems
Commercial vehicle central lubrication systems
Progressive distributors
Control and monitoring devices

This document is intended solely as a means of evaluation and to provide you with data to assist you in using our product. Product performance is influenced by many factors outside the control of Groeneveld-BEKA. Groeneveld-BEKA products are sold in accordance with the Groeneveld-BEKA terms and conditions of sale, which include our limited warranty and remedies. You can find them at <https://www.groeneveld-beka.com/en/>
Specifications are subject to change without notice. For further information and support, please contact your technical contact at Groeneveld-BEKA.
Every reasonable effort has been made to ensure the accuracy of the information in this document, but no liability is accepted for errors, omissions or for any other reason.